

# Electromagnetic Design of a New Magnetic Gear with Electrically Controlled Gear Ratios for Hybrid Electric Vehicles

Mu Chen<sup>1</sup>, K.T. Chau<sup>1</sup>, *Fellow, IEEE*, Yubin Wang<sup>2</sup>, and Chunhua Liu<sup>1</sup>

1. Department of Electrical and Electronic Engineering The University of Hong Kong, Hong Kong, China

2. School of Electromechanical Engineering, China University of Petroleum, Qing Dao, China

## I. INTRODUCTION

Hybrid electric vehicles (HEVs) draw more and more attentions due to the energy crisis and environmental pollution. Mechanical gearbox, which is the essential part of HEVs propulsion system, inherently suffers from the drawbacks of contact friction, regular maintenance and annoying noise [1]. Magnetic gears can be the best candidate because they have the merits of silent operation, maintenance free and physical isolation. However, the gear ratio of magnetic gear is fixed whereas the gear ratio of mechanical boxes can be flexibly varied to fulfill for different driving requirements and road conditions.

The purpose of this paper is to propose a new magnetic gear with electrically controlled gear ratios for HEVs propulsion system by combining the concept of magnetic gear and the concept of memory machine. The key is to artfully insert double-deck magnetizing/demagnetizing winding into the stationary ring in such a way the aluminum-nickel-cobalt (Alnico) permanent magnet (PM) pieces can be dynamically magnetized or demagnetized, hence achieving the ability of gear-ratio-change. By using finite element analysis, the electromagnetic performances of the proposed magnetic gear under different gear ratios are simulated and discussed. Hence, the corresponding validity can be verified.

## II. MAGNETIC GEAR DESIGN.

The proposed magnetic gear possesses six workable gear ratios, namely the gear ratios of  $G_r=4/15$ ,  $G_r=5/14$ ,  $G_r=7/12$ ,  $G_r=12/7$ ,  $G_r=14/5$ , and  $G_r=15/4$ . Fig. 1(a) shows the configuration of the proposed magnetic gear which works under  $G_r=12/7$ . The new magnetic gear consists of an inner rotor mounted with Alnico PM pieces, a stationary ring with magnetizing/demagnetizing winding and an outer rotor mounted with Alnico PM pieces. The double-deck stationary ring, which sandwiched between the inner rotor and the outer rotor, performs the flux modulation. Also, the stationary ring accommodates the double-deck magnetizing/demagnetizing windings, in which the magnetizing/demagnetizing windings locate at nineteen slots, the upper-deck windings are used to magnetize or demagnetize the outer-rotor PM poles, and the lower-deck windings is responsible for the inner-rotor PM poles. As shown in Fig. 1(a), the airgap bridges are purposely inserted besides the magnetizing/demagnetizing windings in such a way the flux leakage will decrease during the normal operation.

Furthermore, in order to obtain the ability of magnetization, the Alnico PM material is used in the proposed magnetic gear. The Alnico PM, which offers the merits of high cost-effectiveness and high remnant flux density, is seldom adopted in electric machines for industrial application due to its inherent drawback, namely low coercivity. However, the proposed magnetic gear positively utilizes this demerit to achieve the function of gear-ratio-changing. In addition, the Alnico PM

materials offer the definite advantage of higher Curie temperature compared to other types of PM materials, which is important when working at harsh vehicular environment.

Fig. 1(b) shows the proposed magnetic gear based hybrid propulsion system which consists of an engine, two electric machines, three converters and the proposed magnetic gear. The machine 1 takes the charge of adjusting the position of two rotors during the gear-ratio-changing process and works as integrated started generator during the normal operation. Furthermore, the machine 2 is responsible for supplying extra power and performing regenerative braking.

### III. FINITE ELEMENT ANALYSIS.

By using the finite element analysis, the electromagnetic performances of the proposed magnetic gear are calculated and discussed. The inner rotor of the gear is coupled with the engine via the machine 1 and the outer rotor of the proposed gear serves as the output terminal.

The static torque performances of the proposed magnetic gear under six sets of  $G_r$  are simulated. Namely, the waveforms under  $G_r=4/15$ ,  $G_r=5/14$ ,  $G_r=7/12$ ,  $G_r=12/7$ ,  $G_r=14/5$ , and  $G_r=15/4$  are exhibit in Fig. 2(a), 2(b), 2(c), 2(d), 2(e), and 2(f), respectively. The first three sets of  $G_r$  are to scale down the torque output (namely scale up the speed), whereas the last three sets are to scale up the torque output (namely scale down the speed). Hence, the speed or torque of output shaft can be scaled down or up accordingly to fulfill the different road conditions and driving requirements

From the torque waveforms, it can be seen that the static torque developed at the outer rotor and inner rotor are, respectively 93.2 Nm and 54.3 Nm, under  $G_r=12/7$ . The corresponding torque ripples can be calculated as given by 1.89% and 0.5%. Similarly, the static torques and the torque ripples under other gear ratios can be calculated. It can be deduced that the torques developed at the outer rotor and inner rotor agrees with the value of gear ratios. Also, the torque ripples under all six gear ratios are significantly small.

Finally, with the six workable gear ratios of the proposed magnetic variable gear, namely from 0.26 to 3.75, the vehicle can readily adjust the gear ratio to fulfill different road conditions and driving requirement. It should be noted that the online magnetization or demagnetization of the Alnico PM can be achieved by applying a positive or negative current pulse within only 1 ms. The associated power consumption for such gear changing is insignificant.

The detailed magnetic gear design principle and additional performances will be given in the full paper. This work was support by a grant of HKU710612E from RGC HKSAR.

### REFERENCE

[1] M. Chen, K.T. Chau, W. Li, C. Liu and C. Qiu, "Design and Analysis of a New Magnetic Gear With Multiple Gear Ratios," vol. 24, no. 3, June 2014.

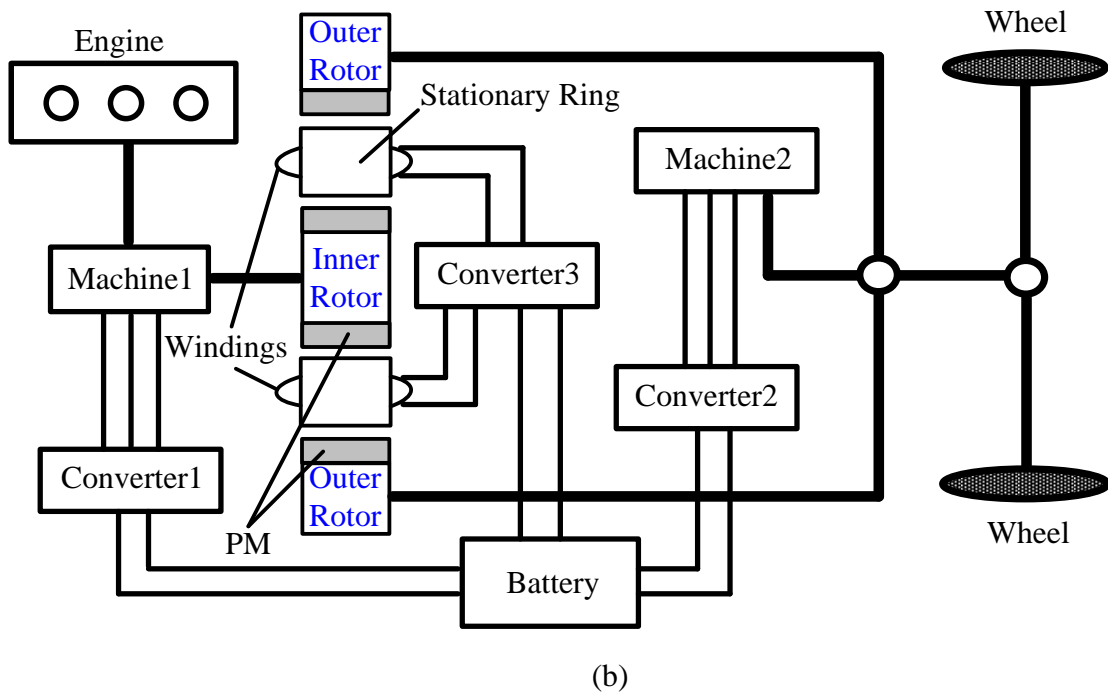
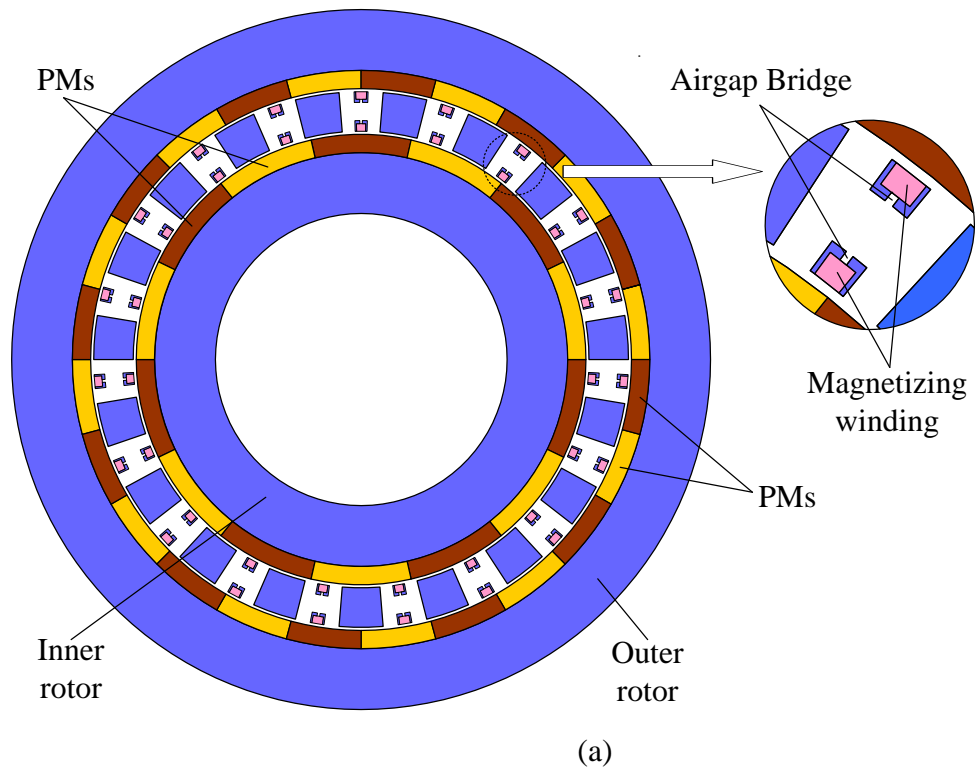

Fig. 1. Proposed magnetic gear. (a) Configuration. (b) Corresponding based hybrid propulsion system.

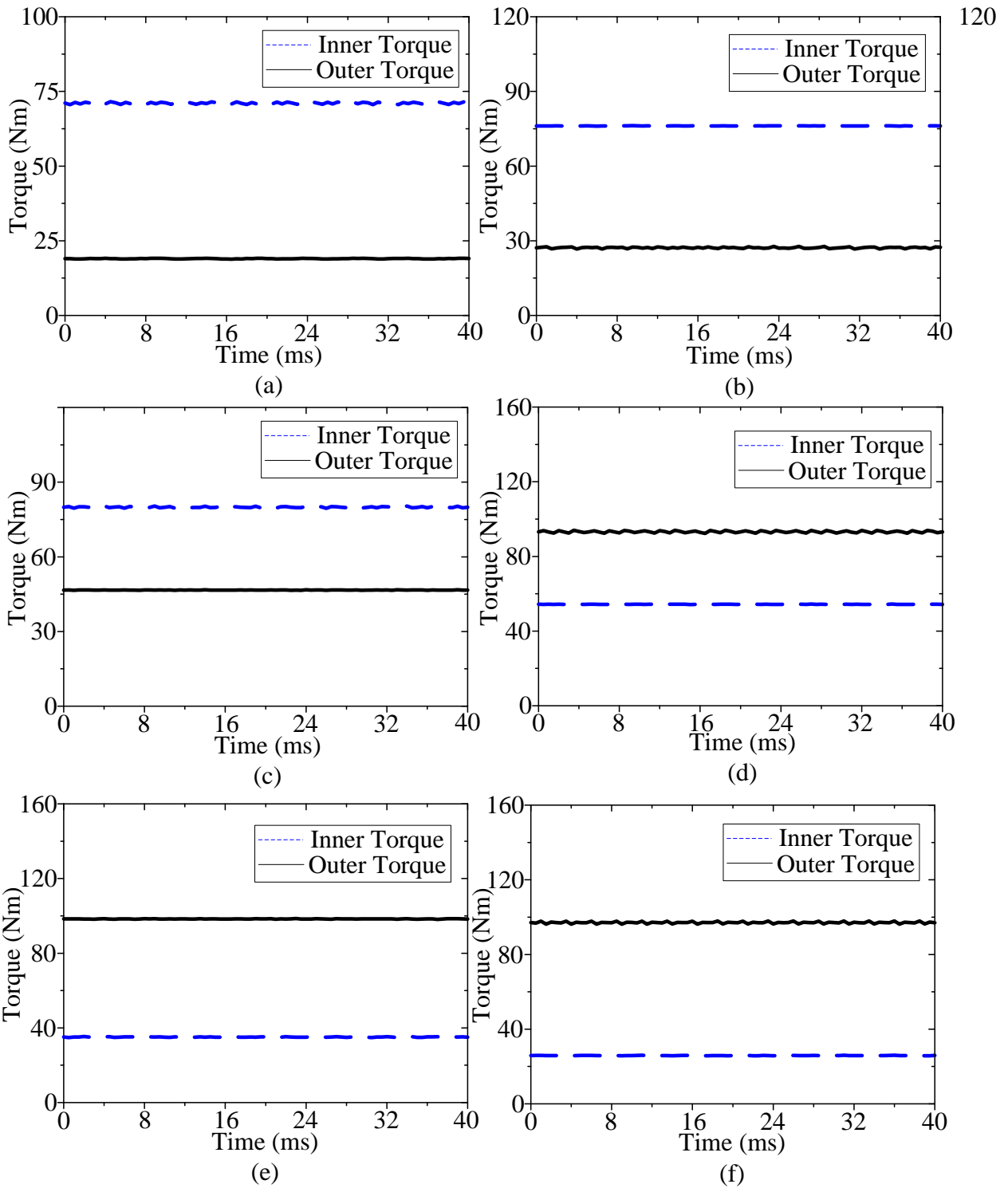

Fig. 2 Electromagnetic performances of the proposed magnetic gear under different gear ratios: (a)  $G_r=4/15$ ; (b)  $G_r=5/14$ ; (c)  $G_r=7/12$ ; (d)  $G_r=12/7$ ; (e)  $G_r=14/5$ ; (f)  $G_r=15/4$ ;