

# Circularly Polarized Monopole Antenna Using CRLH TL Feed Network

Y.F. Cao, S.W. Cheung and T.I. Yuk

Department of Electrical and Electronic Engineering

The University of Hong Kong

Hong Kong, China

[yfcao, swcheung, tiyuk]@eee.hku.hk

**Abstract**—A circularly polarized (CP) monopole antenna with the feed network designed based on using composite right/left-handed transmission line (CRLH TL) is proposed. The CP antenna consists of two monopole elements, a  $90^\circ$ -phase shifter implemented using a CRLH TL unit cell and a Wilkinson power divider. The two monopole elements are designed to operate at a frequency of about 2.3 GHz and placed in perpendicular to each other to generate two orthogonal-electric fields. The power divider divides the input signal into two signals with equal amplitude and phase. One of the signals is fed to a monopole element via the phase shifter, while the other signal is fed directly to the other monopole element. The two signals at the corresponding monopole elements are therefore in phase quadrature, hence generating a CP signal. Simulation results show that the antenna has an impedance bandwidth ( $S_{11} < -10$  dB) of 1.89-3.20 GHz and a wide axial-ratio bandwidth (AR < 3 dB) of 2.08-2.36 GHz.

**Keywords**—circularly polarization, CRLH, monopole, phase shifter, WLAN

## I. INTRODUCTION

Circularly polarized (CP) antennas have many advantages such as mitigating polarization mismatching and avoiding multi-path interference for mobile communication systems. Due to the increasing demands for high-speed communications systems, impedance bandwidth and axial ratio bandwidth (ARBW) are becoming important factors in the design of CP antennas. Very often, CP antennas are designed using slot antennas and different techniques have been proposed [1-9]. In [1-3], asymmetrical slots were cut at the corners of the patch radiators to generate two orthogonal modes with phase quadrature and hence to generate the CP signal. In [4-6], asymmetrical slots were etched in the center of the patch radiators to excite the orthogonal modes with phase quadrature and so to generate the CP signal. In [7, 8], a CP array antenna was designed using four patch elements fed by a sequentially rotated serial-feed network. In [9], two orthogonal sides of a square-ring slot in a slot antenna were excited using a series microstrip line to produce a CP signal. It is relatively easy to design CP antennas using slot antennas or patch antennas.

However, slot antennas and patch antennas theoretically have the disadvantages of larger sizes and less bandwidths compared with those of monopole antennas which therefore have a great potential to be used for the design of CP antennas.

In this paper, a CP antenna employing of two monopole elements as radiators is proposed. The feed network to the monopole elements is composed of a Wilkinson power divider and a phase shifter. In [10], it was shown that a phase shifter designed using CRLH TL unit cells could achieve a wider operating bandwidth [10], thus the phase shifter used in our proposed CP monopole antenna is designed and implemented using a composite right/left-handed transmission line (CRLH TL) unit cell. The objective of the studies is to demonstrate that a wider ARBW can be achieved if the phase shifter of the CP antenna is designed using a CRLH TL unit cell. The study of the proposed CP antenna is carried out using the EM simulation tool CST. Simulation results show that the proposed CP antenna has a wider ARBW than those CP antennas studied in [1-9]. The simulated results on the reflection coefficient, AR, radiation pattern, and realized boresight gains are presented in this paper.

## II. ANTENNA DESIGN

The layout of the proposed CP monopole antenna is shown in Fig. 1, which consists of two simple monopole elements with microstrip-lines fed. The monopole elements have a length of  $\lambda_g/4$ , where  $\lambda_g$  is the guide wavelength at the operating frequency of about 2.3 GHz. The feed network is composed of a Wilkinson power divider which divides the input signal into two signals with equal power and same phase. The two arms of the Wilkinson power divider are  $\lambda_g/4$ -transformers, having a characteristic impedance of  $1.414 \times Z_0$ . At the outputs of the Wilkinson power divider, a chip resistor with a value of  $100 \Omega$  is used to connect the terminals together [11]. One of the signals from the power divider is directly fed to the monopole element on the left of the CP antenna via the  $90^\circ$ -phase shifter, as shown in Fig. 1(a), while the other signal is fed to the other monopole element on the right via a feed line. The microstrip-feed lines have a characteristic impedance of  $50 \Omega$ . The  $90^\circ$ -phase shifter is implemented using a CRLH TL unit cell which has a series of inter-digital fingers to realize the series capacitance and two centrosymmetrical vias shunted to ground on the other side of the substrate to realize the shunt

inductance in the equivalent circuit given in [10]. By adjusting the length of the inter-digital fingers and the distance between the fingers, the unit cell can be designed to produce the required phase shift of about  $90^\circ$  [10]. The feed line on the right of the antenna, due to the propagation delay, will also introduce some phase shift to the signal, so the feed network as a whole is designed in such a way that the signals arriving at the corresponding monopole elements will be in quadrature phase, with the signal to the monopole element on the left leading the phase by  $90^\circ$ . As the two monopole-antenna elements are placed in perpendicular to each other, the CP antenna will generate a left-handed (LH) CP signal. The CP antenna is designed on a substrate with an area of  $80 \times 56 \text{ mm}^2$ , a relative permittivity of 3.66 and a loss tangent of 0.04 using the EM simulation software tool CST. The dimensions of the final design are listed in Table I.

TABLE I. OPTIMIZED DIMENSIONS OF PROPOSED ANTENNA (MM)

$L1$	11.5	$L6$	3.0	$L11$	3.2	$Lg$	55.0	$W3$	0.3
$L2$	2.8	$L7$	11.9	$L12$	31.9	$g1$	1.0	$W4$	1.0
$L3$	6.0	$L8$	2.0	$L13$	5.5	$g2$	0.3	$W5$	4.0
$L4$	3.0	$L9$	6.9	$L14$	30.0	$W1$	1.8	$W_s$	56
$L5$	4.5	$L10$	0.8	$L_s$	80	$W2$	0.9	$h_s$	0.8

### III. SIMULATION RESULTS AND DISCUSSIONS

The simulated S11 and axial ratio (AR) of the proposed monopole CP antenna are shown in Fig. 2. It can be seen that the antenna has several resonances at the frequencies of about 2.0, 2.63 and 3.04 GHz, which lead to a wide impedance bandwidth (for  $S_{11} < -6 \text{ dB}$ ) from 1.89 to 3.2 GHz (1.31 GHz, 51.4%). It is shown later that, with the value of  $S_{11} < -6 \text{ dB}$ , the radiation efficiency is above 70%. The simulated ARBW is from 2.08 to 2.36 GHz (0.28 GHz, 12.6 %) which is narrower than the impedance bandwidth from 1.89 to 3.2 GHz, so the ARBW determines the operation bandwidth of the CP antenna. Within the ARBW, the simulated S11 is between -8 to -9 dB.

The simulated radiation patterns in co-polarization (which is RHCP) and cross-polarization (which is LHCP) at 2.2 GHz (the center frequency of the ARBW) are shown in Fig. 3. Note that as the antenna is designed to be in LHCP, for an observer in the direction of propagation, co-polarization is clockwise circular and cross-polarization is anti-clockwise. The clockwise circular looking into the antenna from the  $+x$  direction is co-polarization, but looking into the antenna from the  $-x$  direction becomes cross-polarization. Fig. 3 shows that the radiation pattern in co-polarization is directional pointing at the  $+x$  direction, but there is no null at the  $-x$  direction. The radiation pattern in cross-polarization has a null at the  $+x$  direction, and points at the  $-x$  direction. These results indicate that the peak gain of the radiation pattern is not pointing at the boresight direction. Thus more studies have been carried out on the 3D radiation patterns and results are shown in Fig. 4. It can be seen that the radiation pattern has a peak gain at  $\theta = 120^\circ$  and  $\phi = 15^\circ$  in LHCP.

The simulated realized boresight gains in co-polarization and cross-polarization are shown in Fig. 5. It can be seen that, within the frequency band for  $AR < 3 \text{ dB}$ , the boresight gain in co-polarization is from -1.3 to -2.5 dBi across the ARBW, while the gain in cross-polarization is lower than -16 dBi. The radiation efficiency is above 70% in the ARBW.

Finally, the ARBW of the proposed CP antenna is compared with some of the other antennas in [1-9] in Table 1. It can be seen that the proposed antenna has a much larger ARBW.

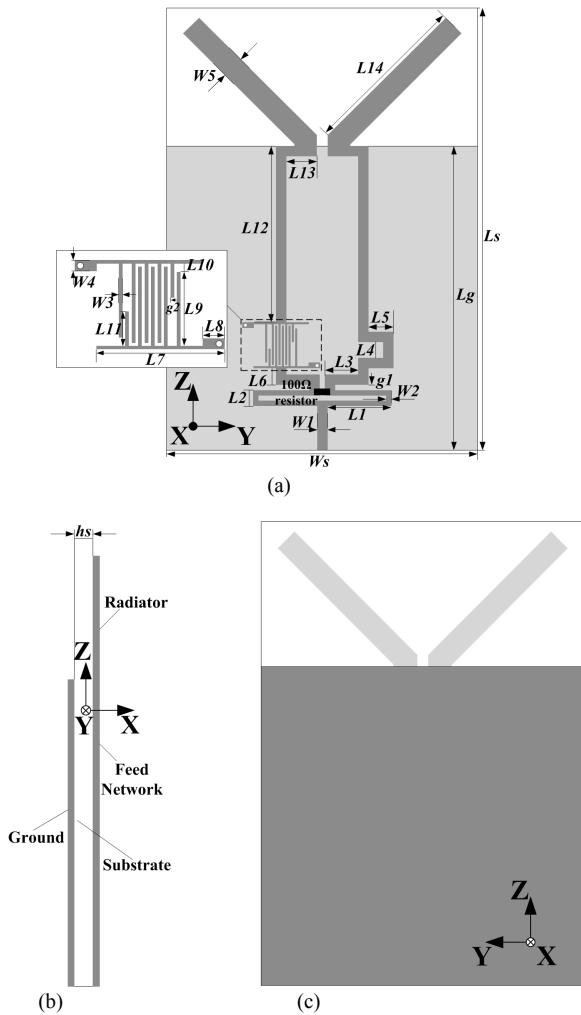

Fig. 1. Geometries of proposed antenna: (a) top view (b) side view (c) bottom view (■ metal on top layer, □ metal on bottom layer)

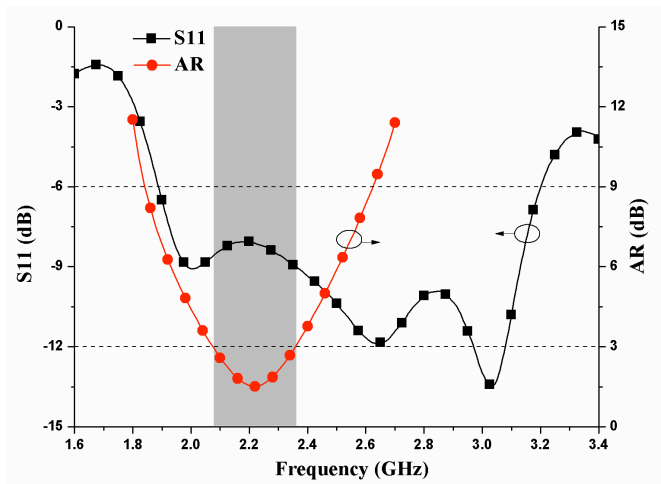

Fig. 2. Simulated S11 and AR

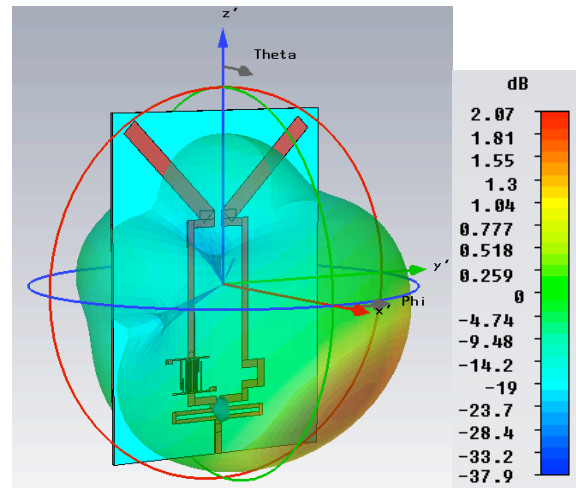

Fig. 4. 3D radiation pattern in LHCP

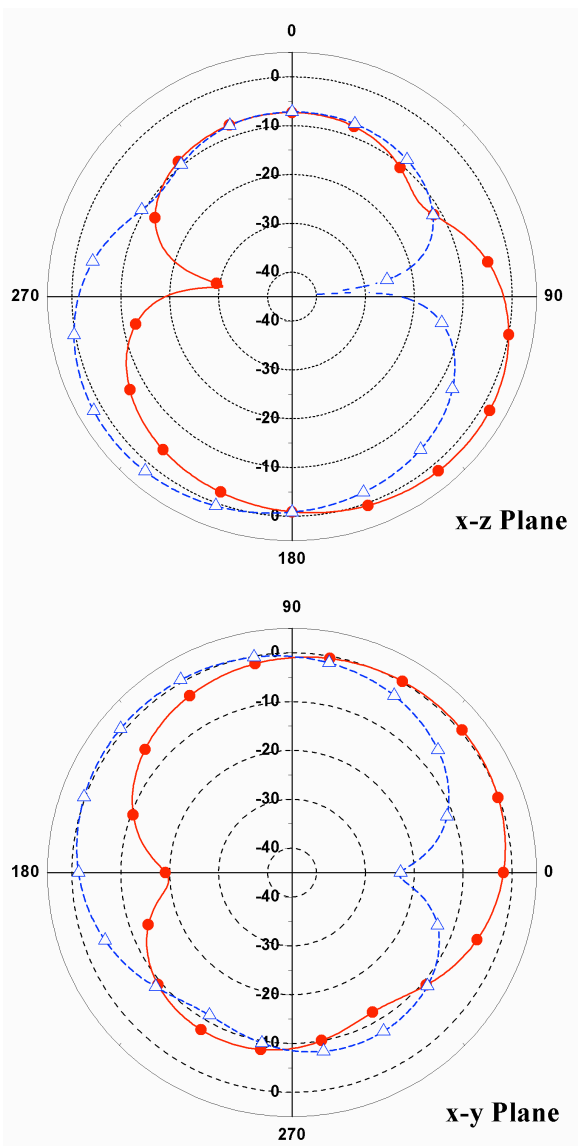

Fig. 3. Simulated radiation patterns at 2.2 GHz (co-polarization —●—, and cross-polarization —△—)

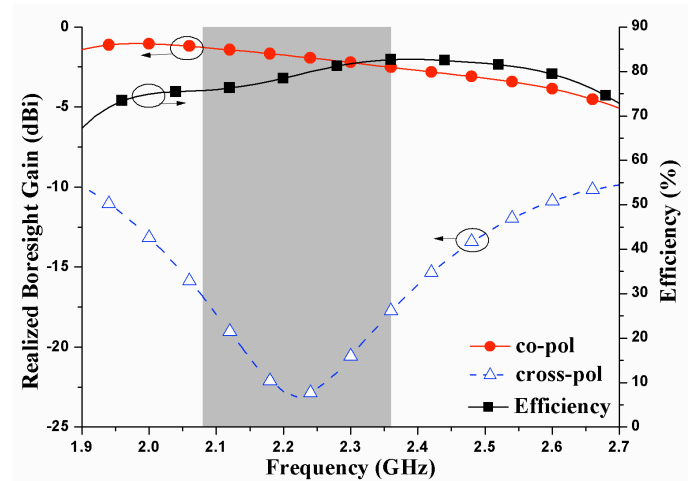

Fig. 5. Simulated efficiencies and gains of co-polarization and cross-polarization

TABLE II. COMPARISON WITH OTHER ANTENNAS IN [1-9]

Ref	Center Frequency (GHz)	ARBW (%)
[1]	2.26	0.84
[2]	2.19	2.1
[3]	2.41	0.5
[4]	1.53	0.75
[5]	2.45	3.3
[6]	10.1	0.8
[7]	2.47	2.0
[8]	2.44	0.82
[9]	1.59	6.3
Proposed antenna	2.22	12.6

#### IV. CONCLUSIONS

A CP monopole antenna with the feed-network based on using CRLH TL has been presented. The antenna consists of two monopole elements as radiators, a feeding network using the Wilkinson power divider, and a  $90^\circ$ -phase shifter implemented using CRLH TL unit cell. Simulated results have showed that the proposed antenna has an ARBW from 2.08 to 2.36 GHz, radiation efficiency of above 70%.

#### REFERENCES

- [1] W. S. Chen, C. K. Wu, and K. L. Wong, "Novel compact circularly polarized square microstrip antenna," *IEEE Trans. Antennas Propag.*, vol. 49, NO. 3, pp. 340-342, Mar. 2001.
- [2] H. D. Chen, "Compact circularly polarised microstrip antenna with slotted ground plane," *Electron Lett.*, vol. 38, no. 13, pp. 616-617, Jun. 2002.
- [3] Nasimuddin, X. M. Qing, and Z. N. Chen, "Compact asymmetric-slit microstrip antennas for circular polarization," *IEEE Trans. Antennas Propag.*, vol. 59, no. 1, pp. 285-288, Jan. 2011.
- [4] H. Iwasaki, "A circularly polarized small-size microstrip antenna with a cross slot," *IEEE Trans. Antennas Propag.*, vol. 44, no. 10, pp. 1399-1401, Oct. 1996.
- [5] Nasimuddin, and Z.N. Chen, "Aperture-coupled asymmetrical C-shaped slot microstrip antenna for circular polarization," *IET Microw. Antennas Propag.*, vol. 3, no. 3, pp. 372-378, 2009.
- [6] G. Q. Luo, Z. F. Hu, Y. P. Liang, L. Y. Yu, and L. L. Sun, "Development of low profile cavity backed crossed slot antennas for planar integration," *IEEE Trans. Antennas Propag.*, vol. 57, no. 10, pp. 2972-2979, Oct. 2009.
- [7] S. K. Lin, and Y. C. Lin, "A compact sequential-phase feed using uniform transmission lines for circularly polarized sequential-rotation arrays," *IEEE Trans. Antennas Propag.*, vol. 59, no. 7, pp. 2721-2724, Jul. 2011.
- [8] M.N. Jazi and M.N. Azarmanesh, "Design and implementation of circularly polarized microstrip antenna array using a new serial feed sequentially rotated technique," *IEE Proc.-Microw. Antennas Propag.*, vol. 153, no. 2, pp. 133-140, Apr. 2006.
- [9] J. S. Row, "The Design of A Squarer-Ring Slot Antenna for Circular Polarization", *IEEE Trans. Antennas Propag.*, vol. 53, NO. 6, pp. 1967-1972, Jun. 2005.
- [10] J. Zhang, "Designs of True-time-delay Lines and Digital Phase Shifters Using Composite Right/left-handed Transmission Lines," Ph.D. thesis, Dept. Electri. Electron. Eng., The Univ. of Hong Kong, Hong Kong, China, 2012.
- [11] D. M. Pozar, "Microwave engineering," John Wiley & Sons, (4th Edition), 2012, ch. 7, pp. 328-332.