

Bidirectional Soft-Switching Converter-fed Dc Motor Drives

K.T. Chau, T.W. Ching and C.C. Chan
Department of Electrical and Electronic Engineering,
The University of Hong Kong, Pokfulam, HONG KONG

ABSTRACT

Two new soft-switching dc-dc converters, with the capabilities of bidirectional power flow, and soft-switching (either zero-voltage transition or zero-current transition) are developed for dc motor drives. The proposed bidirectional zero-voltage-transition converter possesses the definite advantages that both main transistors and rectifiers can switch with zero-voltage switching (ZVS) and unity device stresses during motoring and regenerating modes of operation. While both the main and auxiliary switches of the bidirectional zero-current-transition converter can operate with zero-current switching (ZCS) and minimum voltage / current stress. These converters are particularly useful for dc traction systems in which both motoring and regenerative braking are desired to have high efficiency.

1. INTRODUCTION

Nowadays, the use of low-inductance dc motors is becoming attractive because of the advantages of higher power density, lower rotor inertia, smoother commutation and lower manufacturing costs. However, it usually suffers from high current ripples, resulting in increased losses and switching stresses. To alleviate this problem, the switching frequency of power converters needs to be increased from less than one to over one hundred kilohertz. With available power devices technologies, hard-switching PWM converters operating at such high frequencies impose high switching losses and switching stresses.

Recently, a number of soft-switching techniques, providing zero-voltage switching (ZVS) or zero-current switching (ZCS) conditions, have been successfully developed for switched-mode power supplies (SMPS) [1]-[5]. Surprisingly, the development of soft-switching converters for dc motor drives has been very little. Even so, it has been assumed that those being developed for SMPS can be directly applicable [6]. Until recently, a systematic evaluation of available soft-switching converters for dc motor drives has been carried out [7]. As a result, these soft-switching converters cannot satisfy the operating requirements of dc motor drives. Apart from suffering excessive voltage and current stresses, they cannot handle bidirectional power flow during regenerative braking.

Different to SMPS, dc motor drives especially for traction applications need regenerative braking. Technically, the dc motor operates as a generator to convert the kinetic energy into the electrical energy while the converter must allow for bidirectional power flow to restore the energy to the power networks or battery systems. This energy-recovery feature is particularly attractive to electric railways and battery-powered electric vehicles.

In this paper, two new soft-switching dc-dc converters, with the capabilities of bidirectional power flow, either with zero-voltage-transition (ZVT) or zero-current-transition (ZCT), are proposed for dc motor drives. Their principle of operation during both motoring and regenerative modes, as well as experimental results will be given.

2. PRINCIPLE OF OPERATION - BIDIRECTIONAL ZVT CONVERTER

Fig. 1 shows the circuit diagram of the proposed bidirectional ZVT converter for dc motor drives. It differs from a conventional bidirectional PWM converter, since the addition of a resonant inductor L_r , a resonant capacitor C_r and two auxiliary switches S_a and $S_{a'}$.

The operating waveforms in the motoring mode are shown in Fig. 2, while the corresponding topological modes are illustrated in Fig. 3. Similarly, the operating waveforms in the regenerating mode are shown in Fig. 4, while the corresponding topological stages are illustrated in Fig. 5. As shown in Figs. 3 and 5, both modes exist seven operating stages within one switching cycle.

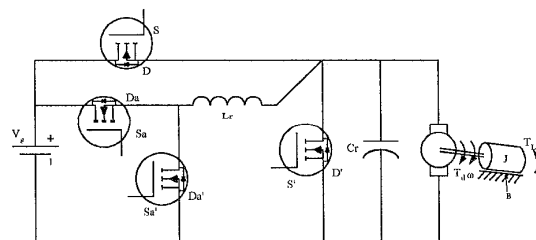

Fig. 1. Proposed bidirectional ZVT converter.

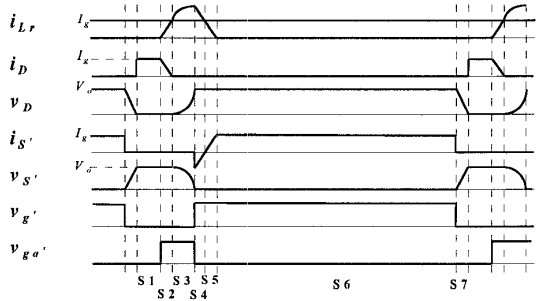
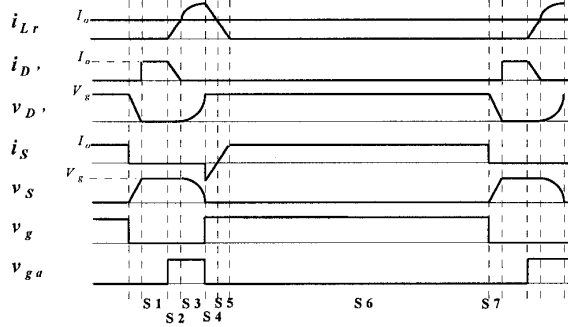
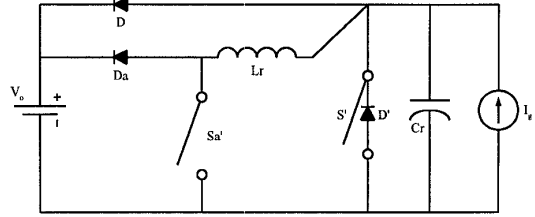
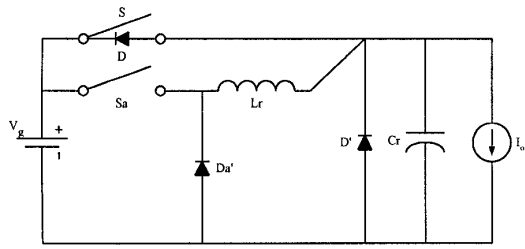

Fig. 2. Equivalent circuit and key waveforms of bidirectional ZVT converter during motoring mode.

Fig. 4. Equivalent circuit and key waveforms of bidirectional ZVT converter during regenerating mode.

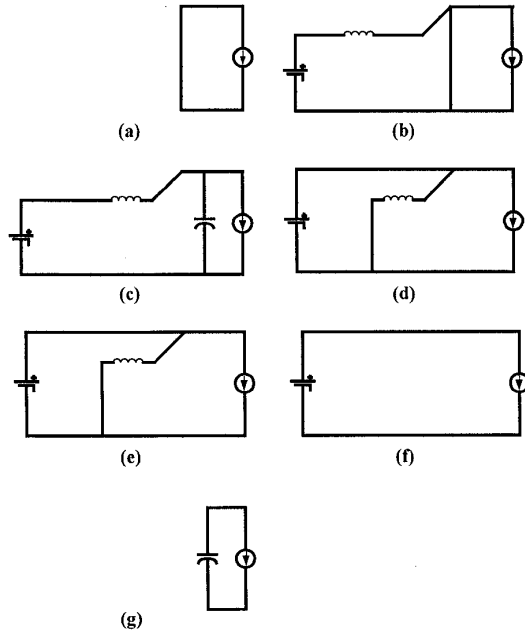

Fig. 3. Seven topological stages of bidirectional ZVT converter during motoring mode.

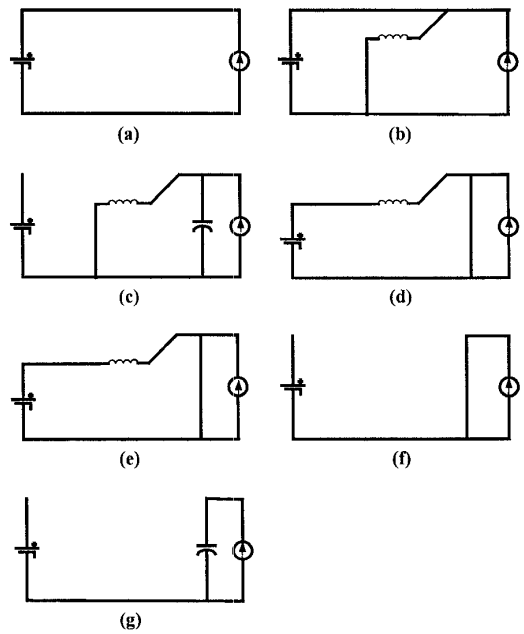

Fig. 5. Seven topological stages of bidirectional ZVT converter during regenerating mode.

2.1 Motoring Mode (Figs. 2 & 3)

- Stage 1 $[T_0-T_1]$: It is a freewheeling mode via D' .
- Stage 2 $[T_1-T_2]$: S_a is turned on. i_{Lr} increases according to the slope of V_g/Lr .
- Stage 3 $[T_2-T_3]$: When $i_{Lr}=I_o$, D' is turned off with ZVS, and Lr and Cr start resonating.
- Stage 4 $[T_3-T_4]$: When v_c reaches V_g , S is turned on with ZVS. S_a is turned off to recover the stored energy in Lr to the source. Then i_{Lr} flows through D_a' and decreases linearly with a slope of V_g/Lr .
- Stage 5 $[T_4-T_5]$: i_{Lr} keeps decreasing while i_S increasing until i_{Lr} reaches zero at T_5 and D_a' becomes off.
- Stage 6 $[T_5-T_6]$: It is a powering mode.
- Stage 7 $[T_6-T_7]$: I_o discharges Cr linearly with a slope of I_o/Cr until v_c equals zero at T_7 , and eventually D' becomes conducting.

2.2 Regenerating Mode (Figs. 4 & 5)

- Stage 1 $[T_0-T_1]$: D is conducting, a regenerating mode.
- Stage 2 $[T_1-T_2]$: S_a' is turned on. i_{Lr} increases with the slope of V_g/Lr .
- Stage 3 $[T_2-T_3]$: When i_{Lr} reaches I_g at T_2 , D is turned off with ZVS, and Lr and Cr start resonating.
- Stage 4 $[T_3-T_4]$: When v_c reaches zero, S' is turned on with ZVS. S_a' is turned off to recover the stored energy in Lr to the source. Then i_{Lr} flows through D_a and decreases linearly.
- Stage 5 $[T_4-T_5]$: i_{Lr} keeps decreasing and i_S' increasing until i_{Lr} reaches zero at T_5 , D_a becomes off.
- Stage 6 $[T_5-T_6]$: It is a freewheeling mode.
- Stage 7 $[T_6-T_7]$: I_g charges Cr linearly with a slope of I_g/Cr until v_c equals V_g at T_7 , and eventually D becomes conducting.

3. PRINCIPLE OF OPERATION - BIDIRECTIONAL ZCT CONVERTER

Fig. 6 shows the circuit diagram of the proposed bidirectional ZCT converter for DC motor drives. Compared with the conventional bidirectional PWM converter, the proposed converter needs additional components -- a resonant inductor Lr , a resonant capacitor Cr and two auxiliary switches S_a and S_a' . It should be noted that these additional components are inevitable for soft-switching operation, and the corresponding hardware count is minimum.

The operating waveforms in the motoring mode are shown in Fig. 7, while the corresponding topological stages are illustrated in Fig. 8. Similarly, the operating waveforms in the regenerating mode are shown in Fig. 9, while the corresponding topological stages are illustrated in Fig. 10. As shown in Figs. 9 and 10, both modes exist nine stages within one switching cycle.

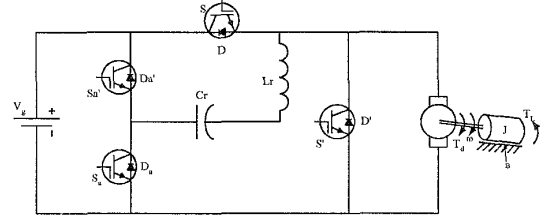

Fig. 6. Proposed bidirectional ZCT converter.

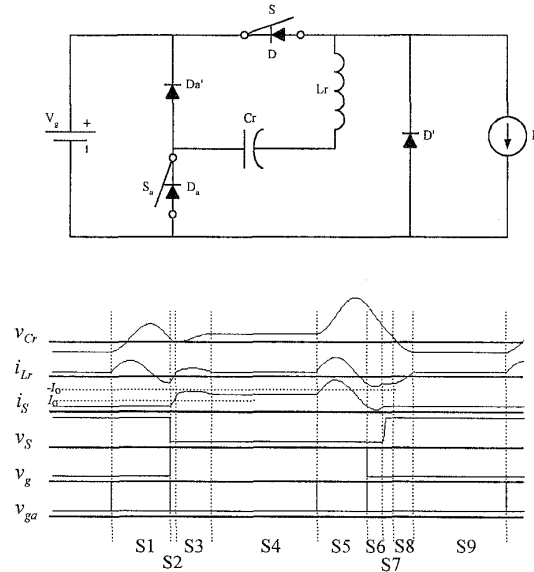

Fig. 7. Equivalent circuit and key waveforms of bidirectional ZCT converter during motoring mode.

3.1 Motoring Mode (Figs. 7 & 8)

- Stage 1 $[T_0-T_1]$: S_a is turned on and Lr and Cr start resonating. When i_{Lr} increases from zero to peak and then decreases toward zero and changes direction. i_{Lr} reaches $-I_o$ at T_1 and the antiparallel diode of S_a becomes on.

- (b) Stage 2 [T_1-T_2]: S_a is turned off and S is turned on with ZCS at T_1 . The current of D' is directed to the auxiliary circuit. i_{Lr} increases rapidly towards zero.
- (c) Stage 3 [T_2-T_3]: i_{Lr} returns to zero at T_2 and the antiparallel diode of S_a is turned off naturally. Lr and Cr continue resonating and the positive i_{Lr} is conducted by D_a' . i_{Lr} returns to zero and D_a' is turned off naturally at T_3 .
- (d) Stage 4 [T_3-T_4]: It is a powering mode
- (e) Stage 5 [T_4-T_5]: Before S is turned off, S_a is turned on again. Lr and Cr start resonating. When i_{Lr} increases from zero to peak and then decreases toward zero and changes direction and reaches $-I_0$ at T_5 and the antiparallel diode of S_a becomes on.
- (f) Stage 6 [T_5-T_6]: At T_5 i_{Lr} reaches $-I_0$ and the current of S is reduced to zero, so S is turned off with ZCS. As i_{Lr} keeps decreasing, and flows through the antiparallel diode of S.
- (g) Stage 7 [T_6-T_7]: At T_6 , i_{Lr} reaches to $-I_0$ and the antiparallel diode of S stops conducting.
- (h) Stage 8 [T_7-T_8]: At T_7 , v_{Cr} is discharged to zero and D' starts to conduct. The current in D' increases gradually.
- (i) Stage 9 [T_8-T_9]: It is a freewheeling mode via D' .

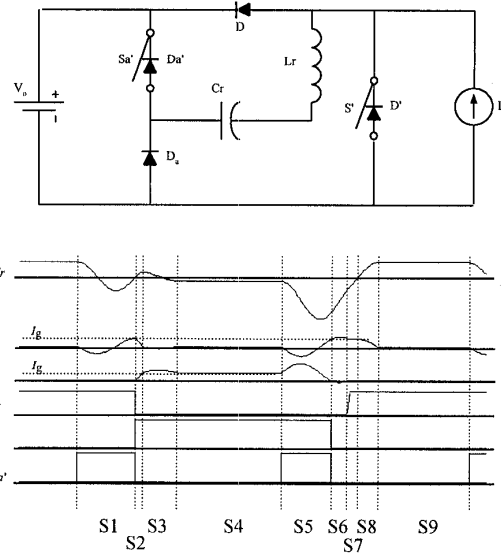

Fig. 9. Equivalent circuit and key waveforms of bidirectional ZCT converter during regenerating mode.

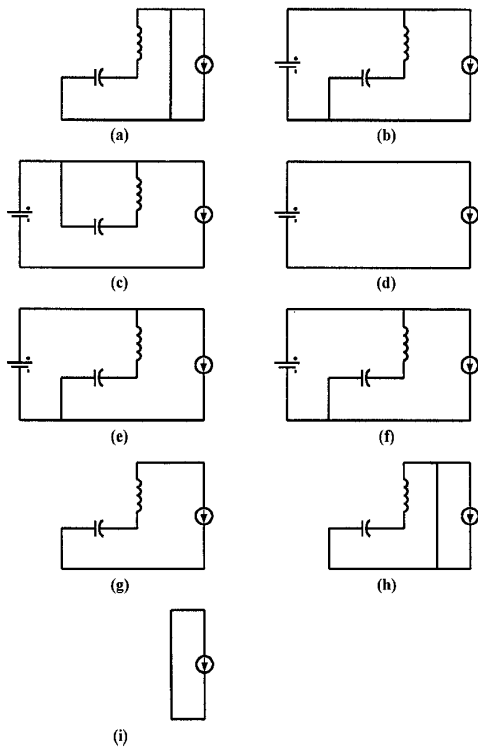

Fig. 8. Nine topological stages of bidirectional ZCT converter during motoring mode.

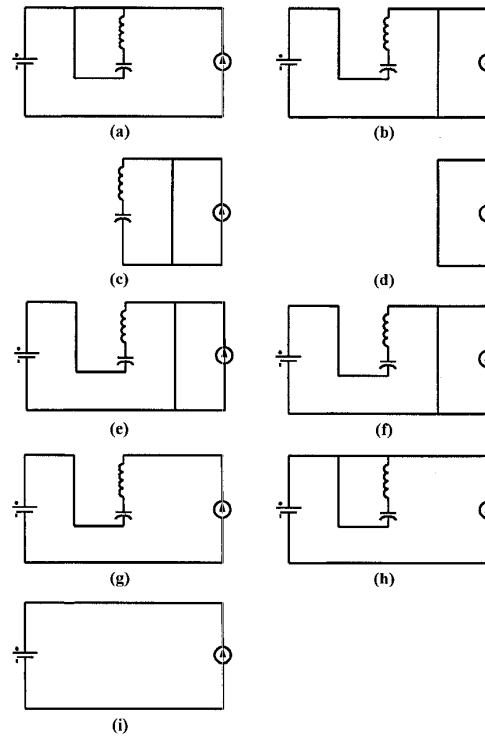

Fig. 10. Nine topological stages of bidirectional ZCT converter during regenerating mode.

3.2 Regenerating Mode (Figs. 9 & 10)

- (a) Stage 1 [T_0-T_1]: S_a' is turned on and L_r and C_r start resonating. When i_{L_r} decreases from zero to negative peak and then increases toward zero and changes direction. i_{L_r} reaches I_g at T_1 and the antiparallel diode of S_a' becomes on.
- (b) Stage 2 [T_1-T_2]: S_a' is turned off and S' is turned on with ZCS at T_1 . The current of D is directed to the auxiliary circuit. i_{L_r} decreases rapidly towards zero.
- (c) Stage 3 [T_2-T_3]: i_{L_r} returns to zero at T_2 and the antiparallel diode of S_a' is turned off naturally. L_r and C_r continue resonating and the negative i_{L_r} is conducted by D_a . i_{L_r} returns to zero and D_a is turned off naturally at T_3 .
- (d) Stage 4 [T_3-T_4]: It is a freewheeling mode
- (e) Stage 5 [T_4-T_5]: Before S' is turned off, S_a' is turned on again. L_r and C_r start resonating. When i_{L_r} decreases from negative zero to peak and then increases toward zero and changes direction and reaches I_g at T_5 and the antiparallel diode of S_a' becomes on.
- (f) Stage 6 [T_5-T_6]: At T_5 reaches I_g and the current of S' is reduced to zero, so S' is turned off with ZCS. As i_{L_r} keeps increasing, and flows through the antiparallel diode of S' .
- (g) Stage 7 [T_6-T_7]: At T_6 , i_{L_r} falls to I_g and the antiparallel diode of S' stops conducting.
- (h) Stage 8 [T_7-T_8]: At T_7 , v_{C_r} is discharged to zero and D starts to conduct. The current in D increases gradually.
- (i) Stage 9 [T_8-T_9]: It is a powering mode via D .

4. SIMULATION AND EXPERIMENTAL RESULTS

To verify the theoretical results, both bidirectional ZVT converter and bidirectional ZCT converter with parameters shown in Figs. 11 & 12 respectively are PSpice-simulated and hardware prototyped.

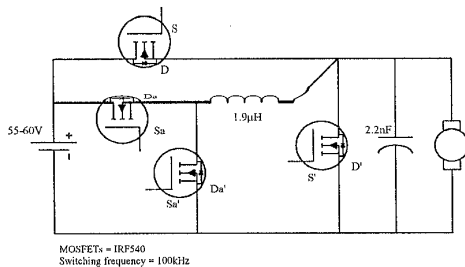

Fig. 11. Experimental bidirectional ZVT converter.

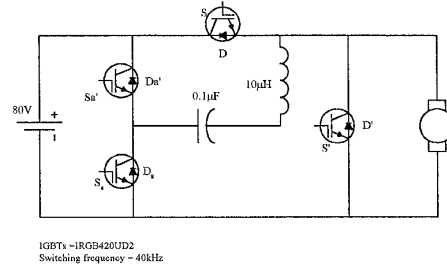

Fig. 12. Experimental bidirectional ZCT converter.

4.1 Bidirectional ZVT Converter (Figs.14,14,17 &18)

From simulation results shown in Figs. 13 and 14, main transistors (i_s , v_s in Fig. 13 and $i_{s'}$, $v_{s'}$ in Fig. 14) and rectifiers (i_D , v_D in Fig. 13 and $i_{D'}$, $v_{D'}$ in Fig. 14) operate with ZVS in both motoring and regenerating modes, and they are subjected to the same voltage and current stresses as those in the PWM counterpart. From the experimental waveforms shown in Figs. 17 and 18, they closely agree with those theoretical waveforms, especially the main switches (S and D' for motoring while S' and D for regenerating) can always maintain ZVS operation.

4.2 Bidirectional ZCT Converter (Figs.15,16,19 &20)

From simulation results shown in Figs. 15 and 16, main and auxiliary transistors operate with ZCS in both motoring and regenerating modes, and they are subjected to the minimum voltage and current stresses. From the experimental waveforms shown in Figs. 19 and 20, they closely agree with those theoretical waveforms, especially the main and auxiliary switches can always maintain ZCS operation.

5. CONCLUSION

Two novel bidirectional soft transition converters for dc motor drives have been presented. The bidirectional zero-voltage-transition converter possesses the definite advantages that both main transistors and rectifiers can switch with zero-voltage switching (ZVS) and unity device stresses. While both the main and auxiliary switches of the bidirectional zero-current-transition converter can operate with zero-current switching (ZCS). They have simple circuit topology and low cost, leading to achieve high switching frequency, high power density and high efficiency. Other key features are the use of the same resonant tank for both forward and backward power flows and the full utilization of all built-in diodes of the power switches, thus minimizing the overall hardware count and cost.

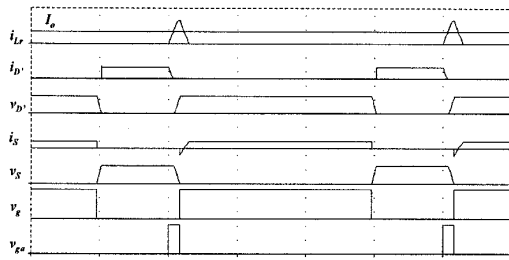

Fig. 13. PSpice simulation of bidirection ZVT converter at motoring mode.

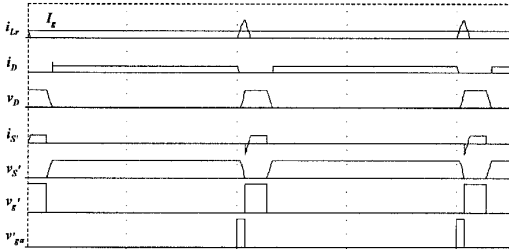

Fig. 14. PSpice simulation of bidirection ZVT converter at regenerating mode.

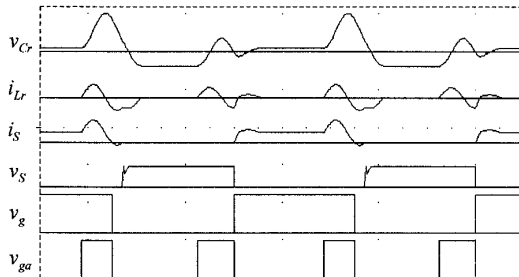

Fig. 15. PSpice simulation of bidirection ZCT converter at motoring mode.

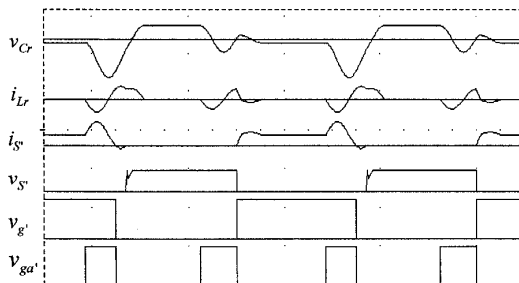

Fig. 16. PSpice simulation of bidirection ZCT converter at regenerating mode.

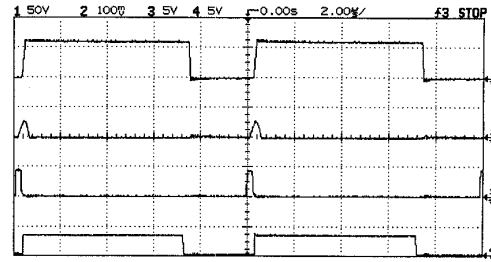

Fig. 17. Measured waveforms of bidirection ZVT converter at motoring (duty ratio = 0.7); v_D (50V/div); i_{Lr} (10A/div), v_{ga} , v_g (5V/div).

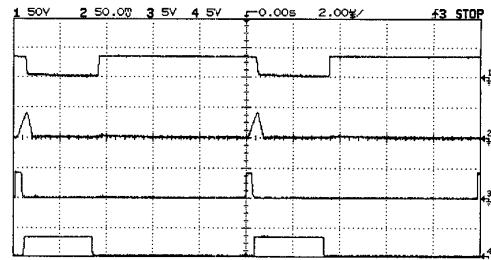

Fig. 18. Measured waveforms of bidirection ZVT converter at regenerating (duty ratio = 0.3); v_s (50V/div); i_{Lr} (5A/div), v_{ga} , v_g (5V/div).

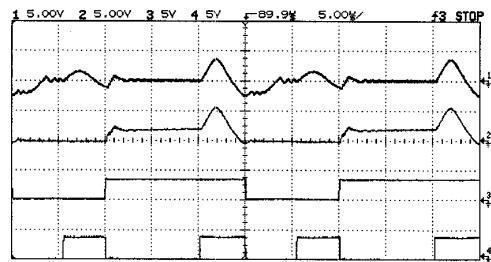

Fig. 19. Measured waveforms of bidirection ZCT converter at motoring (duty ratio = 0.6); i_s (10A/div); i_{Lr} (10A/div), v_{ga} , v_g (5V/div).

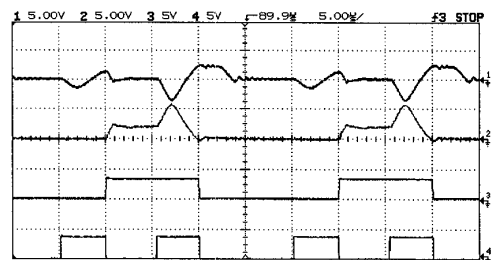

Fig. 20. Measured waveforms of bidirection ZCT converter at regenerating (duty ratio = 0.4); i_s (10A/div); i_{Lr} (10A/div), v_{ga} , v_g (5V/div).

6. ACKNOWLEDGMENT

This work was supported and funded in part by the Committee on Research and Conference Grants, the University of Hong Kong.

7. REFERENCES

- [1] D. Maksimović and S. Čuk, "Constant-frequency control of quasi-resonant converters," *IEEE Trans. Power Electron.*, vol. 6, 1991, pp. 141-150.
- [2] C.C. Chan and K.T. Chau, "A new zero-voltage-switching dc/dc boost converter," *IEEE Trans. Aero. Electron. Syst.*, vol. 29, 1993, pp. 125-134.
- [3] G. Hua, C.S. Leu and F.C. Lee, "Novel zero-voltage-transition PWM converters," In *Proceedings of VPEC Power Electronics Seminar*, 1991, pp. 81-88.
- [4] J.G. Cho, J.W. Baek, G.H. Rim and I. Kang, "Novel zero voltage transition PWM multi-phase converters," In *Proceedings of IEEE APEC*, 1996, pp. 500-506.
- [5] H. Mao, F.C.Y. Lee, X. Zhou, H. Dai, M. Cosan and D. Boroyevich, "Improved zero-current transition converters for high power applications," *IEEE Trans. Ind. Applicat.*, vol. 33, 1997, pp. 1220-1231.
- [6] C.C. Chong, C.Y. Chan and C.F. Foo, "A quasi-resonant converter-fed dc drive system," In *Proceedings of EPE*, 1993, pp. 372-377.
- [7] K.T. Chau, T.W. Ching and C.C. Chan, "Constant-frequency multi-resonant converter-fed dc motor drives," In *Proceedings of IECON*, 1996, pp. 78-83.