



US 20020096429A1

(19) **United States**

(12) **Patent Application Publication**

**Gao et al.**

(10) **Pub. No.: US 2002/0096429 A1**

(43) **Pub. Date: Jul. 25, 2002**

(54) **JOSEPHSON JUNCTIONS WITH A CONTINUALLY GRADED BARRIER**

**Publication Classification**

(76) Inventors: **Ju Gao**, Hong Kong (HK); **Jinglan Sun**, Hong Kong (HK)

(51) **Int. Cl.<sup>7</sup>** ..... **H01L 29/06**; H01L 31/0256

(52) **U.S. Cl.** ..... **204/298.12**; 204/298.21; 257/31; 257/32; 257/33

Correspondence Address:  
**Jones, Day, Reavis and Pogue**  
**North Point**  
**901 Lakeside Avenue**  
**Cleveland, OH 44114 (US)**

(57) **ABSTRACT**

A Josephson junction includes first and second electrodes, each of which is formed of superconductive material. The first electrode has a first electrode face. A barrier of the junction extends from the first electrode to the second electrode. The barrier has a first barrier face opposing and adjoining the first electrode face. The barrier is formed of non-superconductive barrier material and superconductive barrier material. A concentration of the superconductive barrier material is greater than zero at the first barrier face, whereby the first barrier face is formed at least partially of the superconductive barrier material.

(21) Appl. No.: **10/008,022**

(22) Filed: **Nov. 5, 2001**

**Related U.S. Application Data**

(63) Non-provisional of provisional application No. 60/246,172, filed on Nov. 6, 2000.

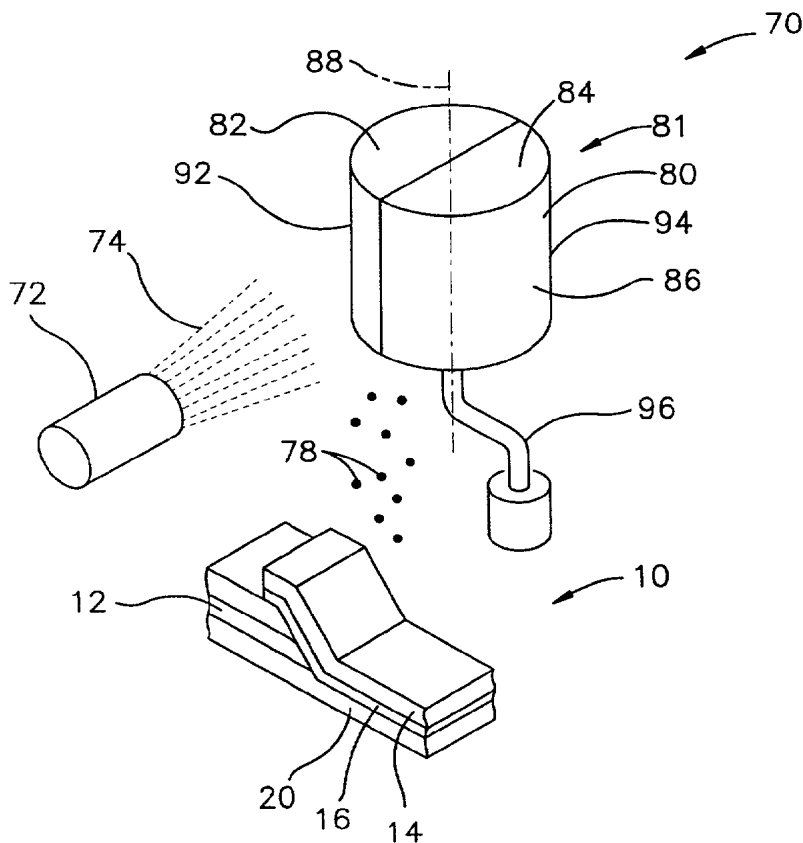

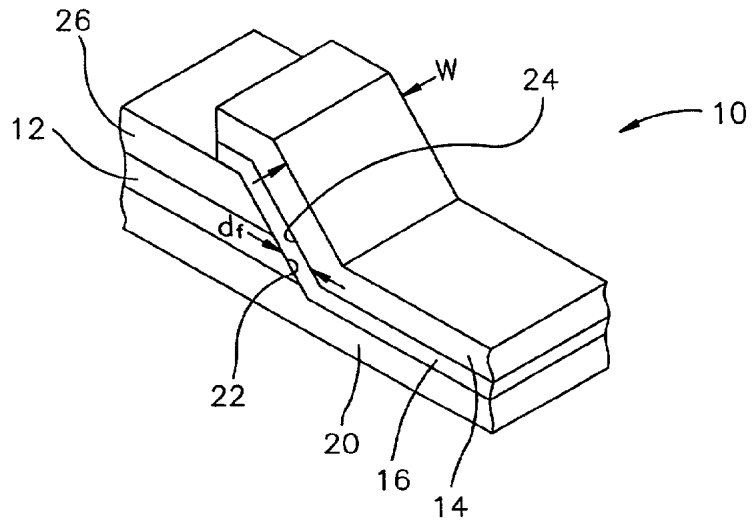

Fig.1

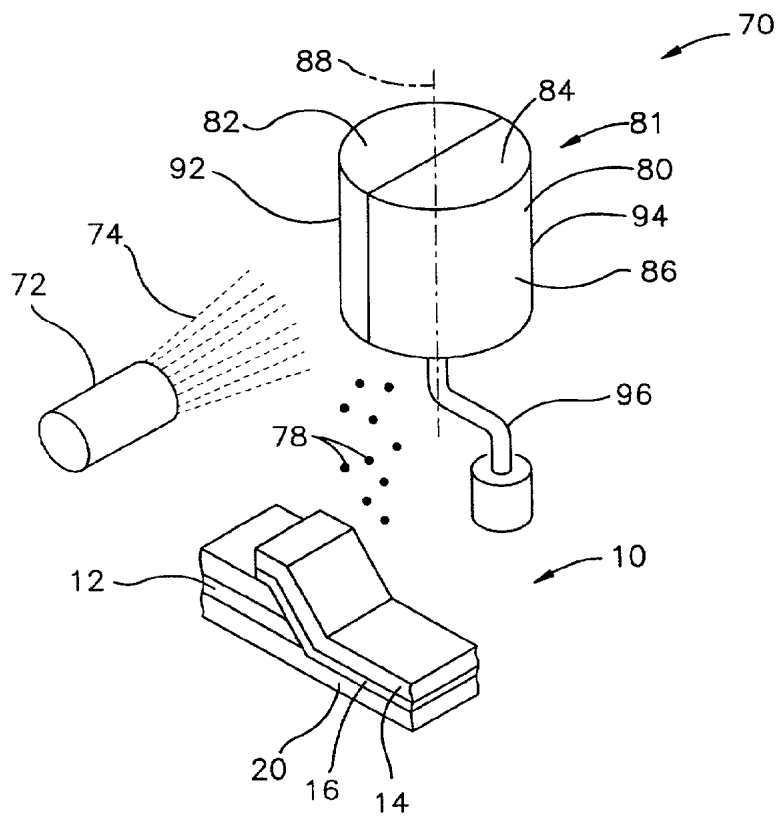

Fig.3

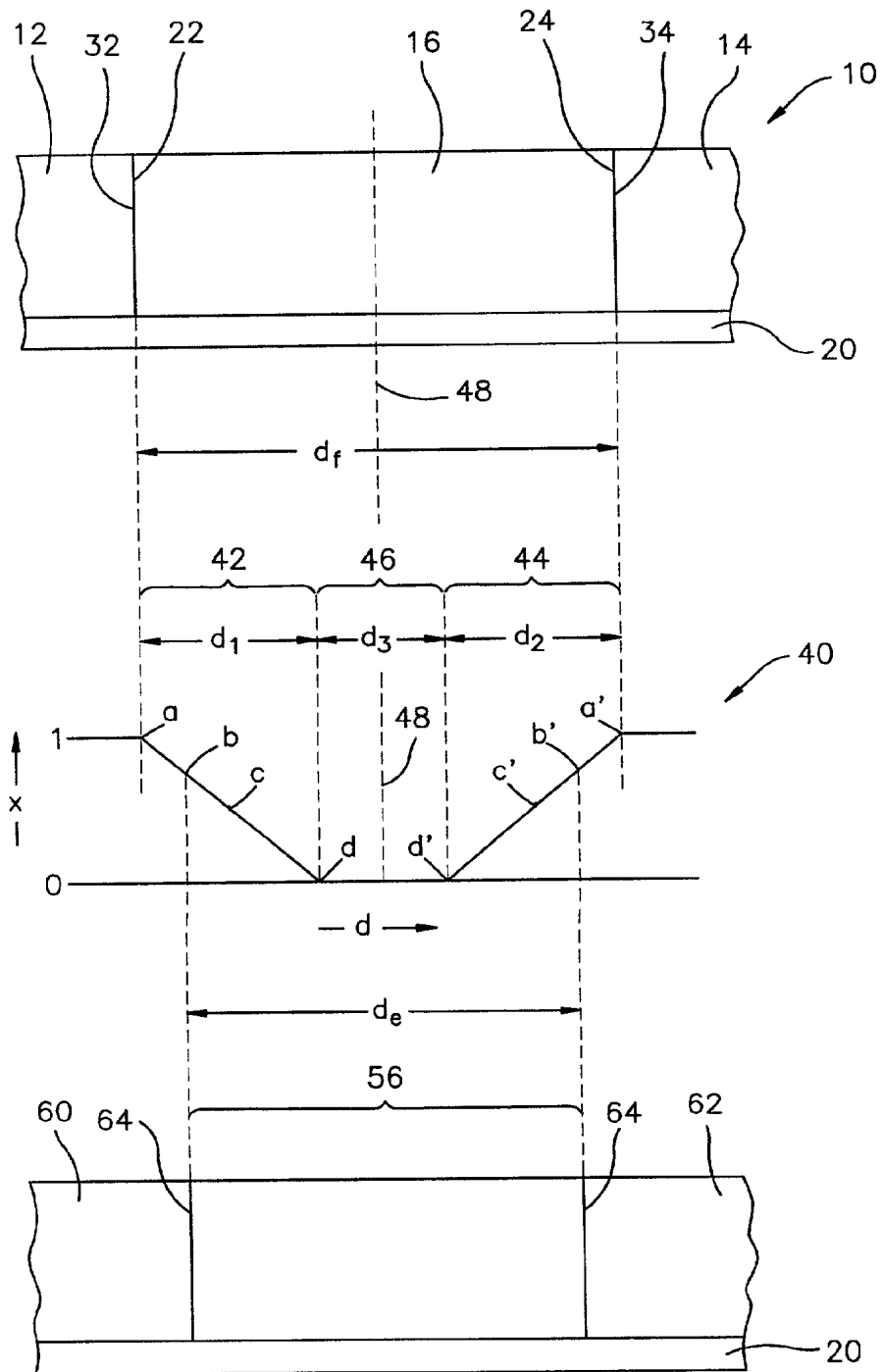

Fig.2

## JOSEPHSON JUNCTIONS WITH A CONTINUALLY GRADED BARRIER

[0001] This application claims the benefit of U.S. Provisional Application No. 60/246,172, filed Nov. 6, 2000.

### FIELD OF THE INVENTION

[0002] The present invention relates to Josephson junctions.

### BACKGROUND

[0003] A Josephson junction has a barrier extending from one superconductive electrode to another superconductive electrode. Under certain conditions, electrons in one of the electrodes can tunnel through the barrier to the other electrode, in accordance with the Josephson effect.

### SUMMARY

[0004] The present invention provides a novel barrier for making Josephson junctions. The Josephson junction comprises first and second electrodes, each of which is formed of superconductive material. The first electrode has a first electrode face. A barrier of the junction extends from the first electrode to the second electrode. The barrier has a first barrier face opposing and adjoining the first electrode face. The barrier is formed of non-superconductive barrier material and superconductive barrier material. A concentration of the superconductive barrier material is greater than zero at the first barrier face, whereby the first barrier face is formed at least partially of the superconductive barrier material.

[0005] In a preferred embodiment of the invention, the concentration of the superconductive barrier material is 100% at the first barrier face, whereby the first barrier face is formed entirely of the superconductive barrier material. The junction has a plurality of distinct contiguous portions extending sequentially from the first electrode to the second electrode. The concentration of the superconductive barrier material is uniform along one of the portions, and the portion is preferably free of the superconductive barrier material. The first and second electrodes are formed of the superconductive barrier material. The concentration of the superconductive barrier material declines away linearly from the first barrier face in a direction toward the second electrode. The superconductive barrier material has a chemical formula. The chemical formula includes Yttrium, and the declining away of the concentration is characterized by the spatially graduated replacement of the Yttrium in the chemical formula by Praseodymium.

[0006] Preferably, the second electrode has a second electrode face, and the barrier further has a second barrier face opposing and adjoining the second electrode face. The concentration of the superconductive barrier material is greater than zero at both barrier faces, whereby both barrier faces are formed at least partially of the superconductive barrier material. Preferably, the concentration of the superconductive barrier material is 100% at both barrier faces, whereby both barrier faces are formed entirely of the superconductive barrier material. The concentration of the superconductive barrier material declines away from the first barrier face in a direction toward the second barrier face and declines away from the second barrier face in a direction toward the first barrier face. The concentration of the super-

conductive barrier material varies symmetrically about a midpoint between the barrier faces.

[0007] The invention also provides a Josephson junction comprising non-superconductive material and superconductive material. The superconductive material is mixed with the non-superconductive material in a spatially varied concentration to yield a spatially varied critical temperature of the junction. The spatially varied critical temperature has minimum and maximum critical temperatures. When the junction is cooled to a temperature between the minimum and maximum critical temperatures, the junction will have two superconducting zones extending from opposite ends of a non-superconducting zone. The length of the superconducting zone and the lengths of the non-superconducting zones in total equals the total length of the junction. The junction will be responsive to a decrease in temperature by effecting an increase in lengths of said superconducting zones and a corresponding decrease in length of said non-superconducting zone.

[0008] The invention further provides an apparatus for a sputtering system having a composite target made of two materials. The sputtering system includes a radiation source and a substrate. The apparatus comprises a target body having a peripheral surface. A first portion of the peripheral surface is formed of a first material to be sputtered from the target and deposited onto the substrate in a first concentration. A second portion of the peripheral surface is formed of a second material to be sputtered from the target and deposited onto the substrate in a second concentration. The target body is configured to enable variation of the first concentration relative to the second concentration by variation of the orientation of the target body relative to the radiation source to thereby vary the areas of the respective surface portions facing the radiation source.

[0009] In a preferred embodiment, the variation of the orientation of the target body is through rotation of the target body. The target body is cylindrical, and the first and second portions are disposed on radially-opposite sides of the cylindrical target.

### BRIEF DESCRIPTION OF THE DRAWINGS

[0010] FIG. 1 is a sectional view of a Josephson junction according to the present invention;

[0011] FIG. 2 is a schematic view of the junction of FIG. 1; and

[0012] FIG. 3 is a schematic view of a sputtering system used in making the junction.

### DESCRIPTION OF THE INVENTION

[0013] The apparatus 10 shown in FIG. 1 has parts which, as described below, are examples of the elements recited in the claims.

[0014] The apparatus 10 is a Josephson junction 10. The junction 10 includes first and 5 second superconductive electrodes 12 and 14. The electrodes 12 and 14 are separated by a barrier 16 that extends from the first electrode 12 to the second electrode 14. The electrodes 12 and 14 are "superconductive" in that they become superconducting when cooled to below a critical temperature. To be "superconducting" is to conduct electricity without resistance. When

the electrodes **12** and **14** are superconducting, electrons in the first electrode **12** can tunnel without resistance through the barrier **16** to the second electrode **14** if the length  $d_f$  of the barrier is sufficiently low. In such a case, the entire junction **10** becomes superconducting, as though the superconducting electrodes **12** and **14** were adjoined directly together without the barrier **16** in-between. This phenomenon is called the Josephson effect.

**[0015]** When exposed to a sufficiently strong magnetic field, the junction **10** loses its superconducting character. The junction **10** can thus serve as an electrical switch by switching off the resistance-less flow of electrons in response to a magnetic field. The sensitivity of the junction **10** in switching off current in response to the magnetic field is related to the barrier length  $d_f$ .

**[0016]** In this example, the junction **10** is ramp-type. The junction **10** is deposited onto a substrate **20** formed of  $\text{SiTiO}_3$ . An insulator **26** is formed over the first electrode **12**.

**[0017]** **FIG. 2** includes a schematic view of the junction **10**, showing the electrodes **12** and **14** and the barrier **16**. Each of the first and second electrodes **12** and **14** is formed of superconductive material. In this embodiment, both electrodes **12** and **14** are formed of the same superconductive material. The material has a chemical formula of  $\text{YBa}_2\text{Cu}_3\text{O}_{7-\delta}$ , which can be represented as  $\text{Y}_x\text{Pr}_{1-x}\text{Ba}_2\text{Cu}_3\text{O}_{7-\delta}$  where  $x=1$ . The first electrode **12** has a first electrode face **22**, and the second electrode **14** has an opposing second electrode face **24**.

**[0018]** A first face **32** of the barrier **16** opposes and adjoins the first electrode face **22**. Similarly, a second face **34** of the barrier **16** opposes and adjoins the second electrode face **24**. The barrier **16** is a composition formed of both the superconductive material and a non-superconductive barrier material. The non-superconductive barrier material has the chemical formula  $\text{PrBa}_2\text{Cu}_3\text{O}_{7-\delta}$ , which corresponds to  $\text{Y}_x\text{Pr}_{1-x}\text{Ba}_2\text{Cu}_3\text{O}_{7-\delta}$  where  $x=0$ .

**[0019]** The parameter  $x$  in the formula  $\text{Y}_x\text{Pr}_{1-x}\text{Ba}_2\text{Cu}_3\text{O}_{7-\delta}$  represents the concentration of the superconductive material within the composition of superconductive and non-superconductive materials. The concentration of the superconductive material is spatially varied within the barrier **16**. This spatial variation is defined by a concentration gradient that extends horizontally, as viewed in the drawings, from the first barrier face **32** to the second barrier face **34**.

**[0020]** In **FIG. 2**, the gradient is represented by a graph **40** of  $x$  vs.  $d$ , where  $d$  represents the distance from the first barrier face **32**, as measured in a horizontal direction from the first barrier face **32** toward the second barrier face **34**. The gradient **40** extends from the first barrier face **32** to the second barrier face **34** and is manifested by the graduated replacement of Yttrium, Y, by praseodymium, Pr, in the formula  $\text{Y}_x\text{Pr}_{1-x}\text{Ba}_2\text{Cu}_3\text{O}_{7-\delta}$ . A concentration of the superconductive material greater than zero is present at both barrier faces **32** and **34**. In this example, both barrier faces **32** and **34** are formed entirely of the superconductive material. This corresponds to a concentration of 100%, represented by  $x=1$ .

**[0021]** The gradient **40** in this example has three distinct regions. Specifically, first and second transition regions **42** and **44** extend from opposite sides of a central region **46**. The

first, second and central regions **42**, **44** and **46** have finite lengths,  $d_1$ ,  $d_2$  and  $d_3$ , respectively.

**[0022]** In both transition regions **42** and **44**, the concentration of the superconductive material declines away from the adjacent barrier face **32** and **34** toward the opposite barrier face **32** and **34**. The declination is smooth and linear, reaching a minimum at the central region **46**.

**[0023]** In general, a superconductive material superconducts only when it is cooled to a temperature at or below a critical temperature  $T_c$ . The critical temperature  $T_c$  is characteristic of the particular chemical formula of that material. The critical temperature  $T_c$  of this particular barrier **16** is spatially varied through the barrier **16**, because the concentration of the superconductive material is spatially varied through the barrier **16**.

**[0024]** Specifically, the concentration of the superconductive material, represented by the parameter  $x$  of  $\text{Y}_x\text{Pr}_{1-x}\text{Ba}_2\text{Cu}_3\text{O}_{7-\delta}$ , declines smoothly from a value of 1 at points a and a' on the gradient **40** to a value of 0 at points d and d'.  $T_c$  is about 90° K at  $x=1$  and decreases with decreasing  $x$ . In other words,  $T_c$  is about 90° K for a 100% concentration of the superconductive material,  $\text{YBa}_2\text{Cu}_3\text{O}_{7-\delta}$ , and decreases with decreasing concentration of the superconductive material. Therefore,  $T_c$  is about 90° K at points a and a'.  $T_c$  is lower at points b and b' than at points a and a'. From points b and b',  $T_c$  decreases further to a temperature of absolute zero (0° K) at points c and c', which correspond to a value of  $x$  of about 0.5. A temperature below absolute zero cannot exist. Therefore,  $T_c$  remains at absolute zero at all points between points c and d and between points c' and d'. Since absolute zero cannot be achieved, all points between c and d and also all points between c' and d' in practice cannot become superconducting.

**[0025]** In the central region **46**, the concentration of the superconductive material is uniform. In this example, the concentration equals zero. Due to the absence of superconductive material in the central region **46**, the central region **46** cannot superconduct at any temperature.

**[0026]** Throughout the barrier **16**, the gradient **40** is symmetric about a plane **48** that is centrally located between and parallel to the barrier faces **32** and **34**. The gradient **40** is also free of a discontinuity in the  $x$  value. The barrier **16** has a minimum critical temperature of 0° K, existing at and between points c and c', and a maximum critical temperature of 90° K, existing at points a and a'.

**[0027]** The following is an example of how the junction **10** functions. The junction **10** is cooled to the maximum critical temperature, which is 90° K. This temperature is equal to  $T_c$  of a 100% concentration of the superconductive material. As noted above, the junction **10** becomes superconducting at each point along the junction **10** at which the temperature is equal to or less than  $T_c$  at that point. Hence, the electrodes **12** and **14** become superconducting, as do the barrier faces **32** and **34**, where the concentration of the superconductive material is 100%. However, along the full length  $d_f$  of the barrier **16** between the barrier faces **32** and **34** where the concentration of superconductive material is less than 100%, the barrier **16** remains non-superconducting at this temperature.

**[0028]** Next, in this example, the junction **10** is cooled further to a temperature equal to  $T_c$  of the material at point

b. This temperature is between the minimum and maximum critical temperatures of the barrier **16**. As stated above, the junction **10** becomes superconducting at each point along the junction **10** for which the temperature is equal to or less than  $T_c$  at that point. Hence, the electrodes **12** and **14** superconduct, as do all points along the barrier **16** between points a and b and between points a' and b'. The barrier **16** remains non-superconducting along a length  $d_c$  between points b and b', which is less than the full barrier length  $d_p$ . The length over which the barrier **16** is non-superconducting has thus been shortened by cooling the junction **10** to the lower temperature.

[0029] If the junction **10** is cooled still further to a yet lower temperature, the barrier **16** becomes non-superconducting along a still smaller length. Conversely, if the junction **16** is warmed, the barrier **16** becomes non-superconducting over a greater length. Therefore, at a temperature between the minimum and maximum temperatures,  $0^\circ$  K and  $90^\circ$  K, the junction **10** comprises first and second superconducting zones **60** and **62** extending from opposite ends **64** and **66** of a non-superconducting zone **56**. The non-superconducting zone **56** has a length  $d_c$  that can be changed by changing the temperature. More specifically, the length of the non-superconducting zone **56** can be reduced by reducing the temperature and can be increased by increasing the temperature.

[0030] However, the length of the non-superconducting zone **56** can never become shorter than the distance between points c and c'. This is because each point between points c and c' lacks superconductive material in sufficient concentration to become superconducting, as noted above.

[0031] The Josephson junction **10** described above can be made through use of a sputtering system. A suitable sputtering system **70** is shown schematically in FIG. 3. The sputtering system **70** has a source **72** of radiation **74**, such as ions, used to sputter target material **78** from the body **80** of a target **81**. The target material **78** is deposited onto the substrate **20** to form the electrodes **12** and **14** and the barrier **16**.

[0032] The target body **80** is formed of first and second target sections **82** and **84** adjoined together to define a cylindrical peripheral surface **86** centered on an axis **88**. The first target section **82** is formed of a first material to be sputtered from the target body **80** and deposited onto the substrate **20** in a first concentration. In this example, the first material is  $YBa_2Cu_3O_{7-\delta}$ . The second target section **84** is formed of a second material to be sputtered from the target body **80** and deposited onto the substrate **20** in a second concentration. In this example, the second material is  $PrBa_2Cu_3O_{7-\delta}$ . The first concentration thus corresponds to the parameter x of  $Y_xPr_{1-x}Ba_2Cu_3O_{7-\delta}$  as described above.

[0033] The peripheral surface **86** thus has a first surface portion **92** formed of the first material and a radially oppositely facing second surface portion **94** formed of the second material. An operator can rotate the target body **80** about its axis **88**, thereby varying the orientation of the target body **80** relative to the radiation source **72**. This rotation can be achieved through use of any suitable rotator **96**, such as an electrically-driven motor or a manually-driven mechanism.

[0034] In operation, the first concentration relative to the second concentration, and hence the parameter x, can be

controlled by controlling the orientation of the target body **80** relative to the ion source **72**. For example, if the target body **80** is oriented such that only the first surface portion **92** faces the ion source **72**, only the first material will be sputtered and deposited onto the substrate **20**. Similarly, if only the second portion **94** faces the ion source **72**, only the second material will be deposited onto the substrate **20**. If both the first and second portions **92** and **94** partially face the ion source **72**, both materials will be deposited. The relative concentrations of these two materials that will be deposited is related to the relative areas of the respective surface portions **92** and **94** facing the ion source **72**.

[0035] This written description uses examples to disclose the invention, including the best mode, and also to enable any person skilled in the art to make and use the invention. The patentable scope of the invention is defined by the claims, and may include other examples that occur to those skilled in the art. Such other examples are intended to be within the scope of the claims if they have structural elements that do not differ from the literal language of the claims, or if they include equivalent structural elements with insubstantial differences from the literal language of the claims.

1. A Josephson junction comprising:

first and second electrodes, each of which is formed of superconductive material, said first electrode having a first electrode face; and

a barrier extending from said first electrode to said second electrode, said barrier having a first barrier face opposing and adjoining said first electrode face;

said barrier being formed of non-superconductive barrier material and superconductive barrier material, with a concentration of said superconductive barrier material being greater than zero at said first barrier face, whereby said first barrier face is formed at least partially of said superconductive barrier material.

2. A Josephson junction as defined in claim 1 wherein said concentration of said superconductive barrier material is 100% at said first barrier face, whereby said first barrier face is formed entirely of said superconductive barrier material.

3. A Josephson junction as defined in claim 1 wherein said junction has a plurality of distinct contiguous portions extending sequentially from said first electrode to said second electrode, and said concentration of said superconductive barrier material is uniform along one of said portions.

4. A Josephson junction as defined in claim 3 wherein said one of said portions is free of said superconductive barrier material.

5. A Josephson junction as defined in claim 1 wherein said first and second electrodes are formed of said superconductive barrier material.

6. A Josephson junction as defined in claim 1 wherein said concentration of said superconductive barrier material declines away from said first barrier face in a direction toward said second electrode.

7. A Josephson junction as defined in claim 6 wherein said concentration of said superconductive barrier material declines away linearly from said first barrier face in a direction toward said second electrode.

8. A Josephson junction as defined in claim 6 wherein said superconductive barrier material has a chemical formula,

and said declining away of said concentration is characterized by the spatially graduated replacement of one element in said chemical formula by another element.

9. A Josephson junction as defined in claim 8 wherein said chemical formula includes Yttrium, and said declining away of said concentration is characterized by the spatially graduated replacement of said Yttrium in said chemical formula by Praseodymium.

10. A Josephson junction as defined in claim 1 wherein said second electrode has a second electrode face, and said barrier further has a second barrier face opposing and adjoining said second electrode face, and said concentration of said superconductive barrier material is greater than zero at both barrier faces, whereby both barrier faces are formed at least partially of said superconductive barrier material.

11. A Josephson junction as defined in claim 10 wherein said concentration of said superconductive barrier material is 100% at both barrier faces, whereby both barrier faces are formed entirely of said superconductive barrier material.

12. A Josephson junction as defined in claim 10 wherein said concentration of said superconductive barrier material declines away from said first barrier face in a direction toward said second barrier face and declines away from said second barrier face in a direction toward said first barrier face.

13. A Josephson junction as defined in claim 10 wherein said concentration of said superconductive barrier material varies symmetrically about a plane that is centrally located between the barrier faces.

14. A Josephson junction comprising:

non-superconductive material; and

superconductive material mixed with said non-superconductive material in a spatially varied concentration to yield a spatially varied critical temperature of said junction, said spatially varied critical temperature having minimum and maximum critical temperatures, such that, when said junction is cooled to a temperature between said minimum and maximum critical temperatures, said junction will have two superconducting

zones extending from opposite ends of a non-superconducting zone such that the length of the superconducting zone and the lengths of the non-superconducting zones in total equal the total length of the junction, and said junction will be responsive to a decrease in temperature by effecting an increase in lengths of said superconducting zones and a corresponding decrease in length of said non-superconducting zone.

15. A Josephson junction as defined in claim 14 wherein said superconductive material has a chemical formula that includes Yttrium, and said spatially varied concentration is characterized by the spatially graduated replacement of said Yttrium in said chemical formula by Praseodymium.

16. An apparatus for a sputtering system having a radiation source and a substrate, said apparatus comprising:

a target body having a peripheral surface;

a first portion of said peripheral surface formed of a first material to be sputtered from said target and deposited onto the substrate in a first concentration;

a second portion of said peripheral surface formed of a second material to be sputtered from said target and deposited onto the substrate in a second concentration;

said target body being configured to enable variation of said first concentration relative to said second concentration by variation of the orientation of said target body relative to the radiation source to thereby vary the areas of the respective surface portions facing the radiation source.

17. An apparatus as defined in claim 16 wherein said variation of the orientation of said target body is through rotation of said target body.

18. An apparatus as defined in claim 16 wherein said target body is cylindrical.

19. An apparatus as defined in claim 18 wherein said first and second portions are disposed on radially-opposite sides of said cylindrical target.

\* \* \* \* \*