



US 20030215906A1

(19) **United States**

(12) **Patent Application Publication**
Lim

(10) **Pub. No.: US 2003/0215906 A1**

(43) **Pub. Date: Nov. 20, 2003**

(54) **RECOMBINANT BACILLUS PROTEASES
AND USES THEREOF**

Publication Classification

(76) Inventor: **Boon Leong Lim, Pokfulam (HK)**

(51) **Int. Cl.⁷** **C12P 21/02**; C12N 9/08;
C12N 9/16; C12N 9/24; C12N 9/56;
C12N 1/21; C12N 15/74
(52) **U.S. Cl.** **435/69.1**; 435/252.31; 435/320.1;
435/196; 435/200; 435/192;
435/222

Correspondence Address:
PENNIE & EDMONDS LLP
1667 K STREET NW
SUITE 1000
WASHINGTON, DC 20006

(57) **ABSTRACT**

(21) Appl. No.: **10/146,905**

(22) Filed: **May 17, 2002**

The present invention provides genetically engineered Bacillus strains that can secrete large amount of Bacillus proteases in the extracellular culture medium. More particularly, this invention relates to a process of producing recombinant protease molecules of Bacillus origin in a *Bacillus subtilis* strain 168, utilizing a strong prophage promoter.

Figure 1.

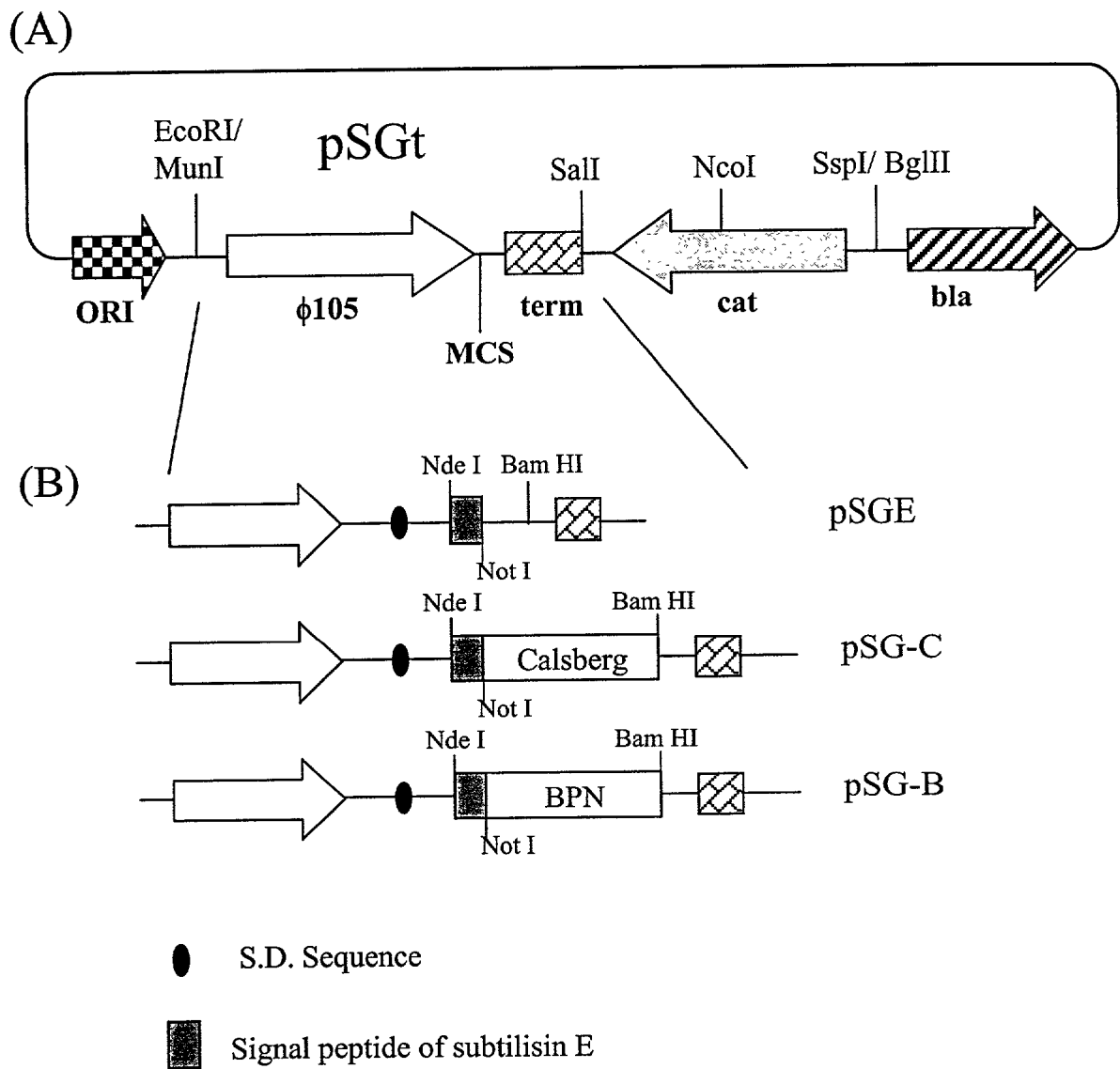
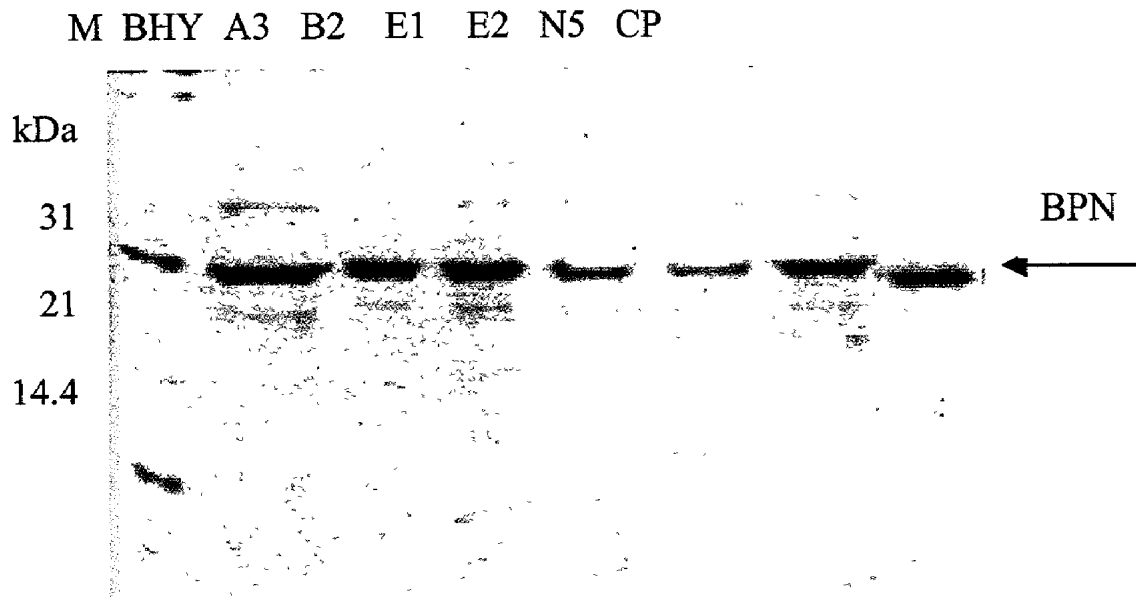

Figure 2.

Carlsberg	1	<i>MRSKKLWISL LFALTLIFTM AFSNMSAQAA</i>	-AQP	AKNVEK	DYIVGFKSGV	50
BPN	1	<i>MRSKKLWISL LFALTLIFTM AFSNMSAQAA</i>	AGKS	NGEKKY	IVGFKQTMST	
	50					
Carlsberg	51	<i>KTASVKKDII KESGGKVDKQ FRIINA</i>	AKAK	LDKEALKEVK	NDPDVAYVEE	100
BPN	51	<i>MSAAKKKDKVI SEKGGKQKQ FKYV</i>	DAASAT	LNEKAVKELK	KDPSVAYVEE	
	100					
Carlsberg	101	<i>DHVAHALAQT VPYGIPLIKA DKVQA</i>	QGFKG	ANVKVAVLDT	GIQASHPDLN	
BPN	101	<i>DHVAHAYAQS VPYGVSQIKA PALHS</i>	QGYTG	SNVKVAVIDS	GIDSSHPDLK	
	150					
Carlsberg	151	<i>VGGASFVAG EAYNTXDGNG HGTHV</i>	VAGTVA	ALDNTTGVLG	VAPSVSLYAV	
BPN	151	<i>VAGGASMVPS ETNPFQDNNS HGTHV</i>	VAGTVA	ALNNSIGVLG	VAPSASLYAV	
	200					
Carlsberg	201	<i>KVLNSSGSGT YSGIVSGIEW ATTNG</i>	MDVIN	MSLGGPSGST	AMQAVDNAY	
BPN	201	<i>KVLGADGSGQ YSWIINGIEW AIANN</i>	MDVIN	MSLGGPSGSA	ALKAAVDKAV	
	250					
Carlsberg	251	<i>ARGVVVAAA GNSGSSGNTN TIGYPA</i>	KYDS	VIAVGAVDSN	SNRASFS	300
BPN	251	<i>ASGVVVAAA GNEGTS</i>	GSSS	TVGYPGKYP	S VIAVGAVDSS	NQRASFS
	300					
Carlsberg	301	<i>AELEVMAPGA GVYSTYPTST YATL</i>	NGTSMA	SPHVAGAAAL	ILSKHPNLSA	350
BPN	301	<i>PELDVMAPGV SIQSTLPGNK YGAY</i>	NGTSMA	SPHVAGAAAL	ILSKHPNWTN	350
	350					
Carlsberg	351	<i>SQVRNRLSST ATYLGSSFY</i>	GKGLINVEAA	AQ*.....	400
BPN	351	<i>TQVRSSLENT TTKLGDSFY</i>	GKGLINVQAA	AQ*.....	400

Figure 3.

(A) Overexpression of protease BPN in various media



(B) Overexpression of protease Carlsberg in various media

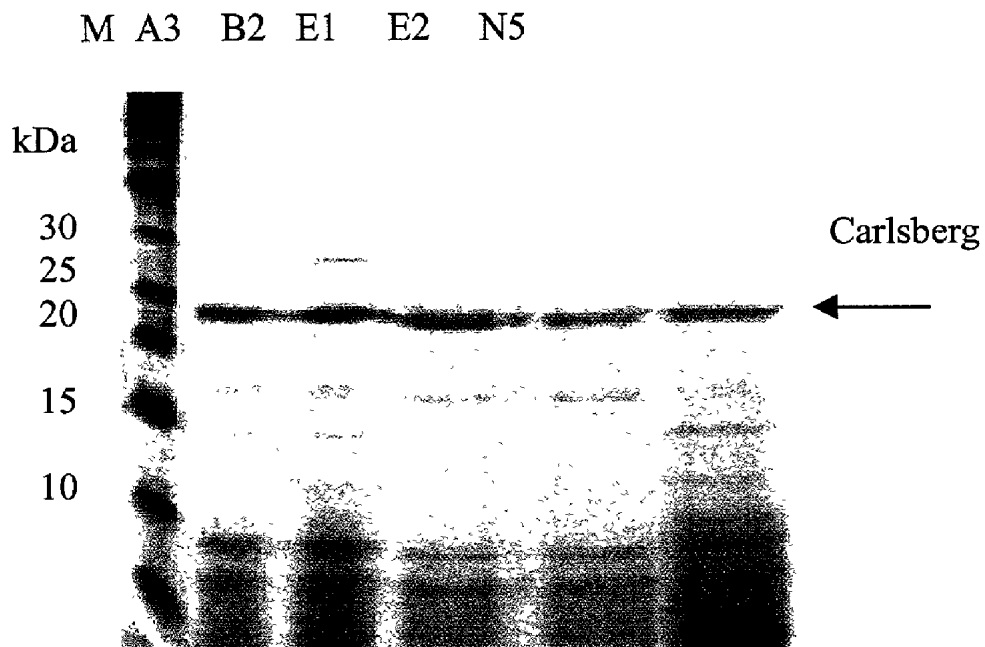
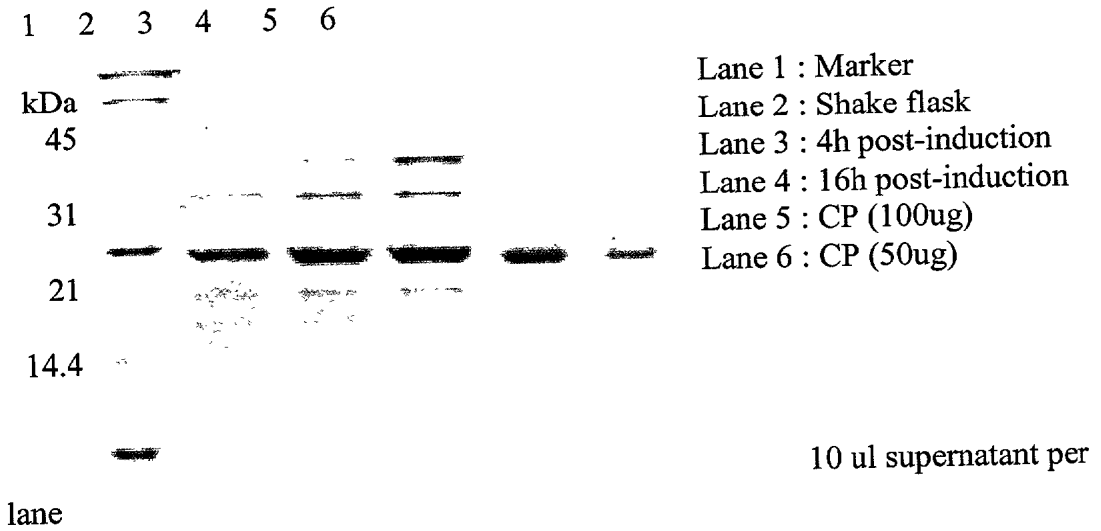

Figure 4.

(A) Expression of protease BPN in a 2L fermentor



(B) Expression of protease Carlsberg in a 2L fermentor

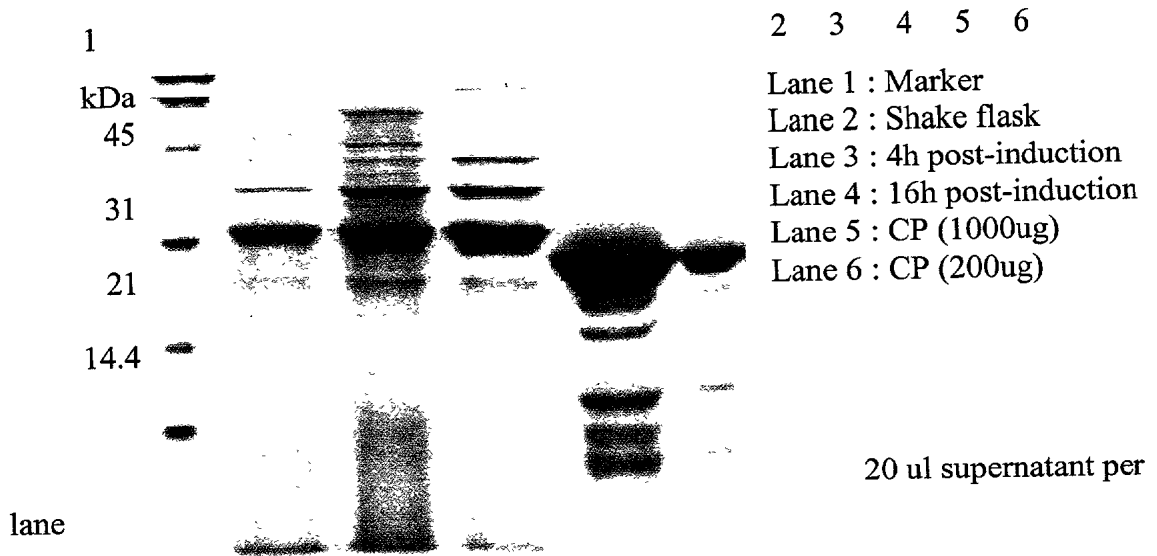

Figure 5.

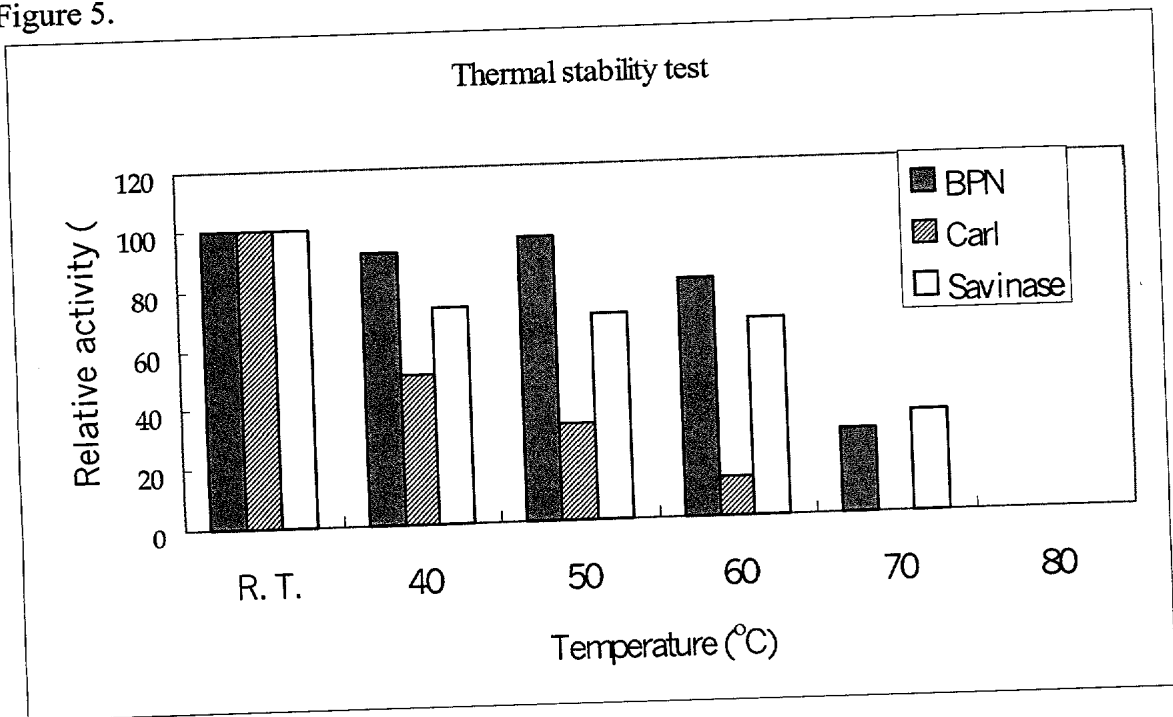
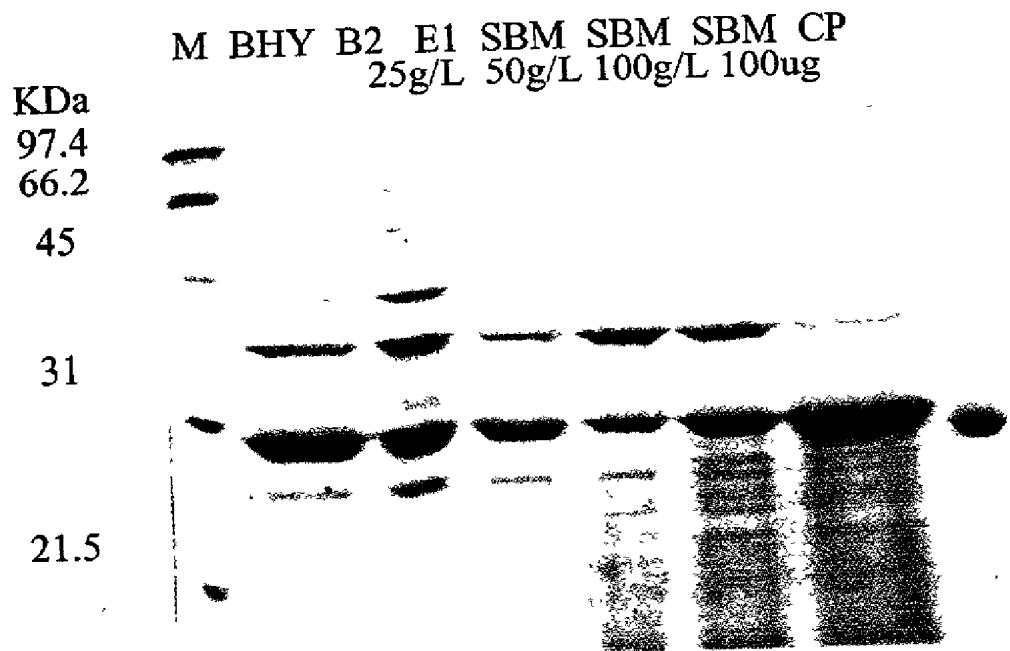

Figure 6.



RECOMBINANT BACILLUS PROTEASES AND USES THEREOF

FIELD OF THE INVENTION

[0001] In this invention, a rapid expression system for *Bacillus* proteases was established. Genetically engineered *Bacillus* strains that can secrete large amount of *Bacillus* proteases in the extracellular culture medium were generated. More particularly, this invention relates to a process of producing recombinant protease molecules of *Bacillus* origin in a *Bacillus subtilis* strain 168, utilizing a strong prophage promoter.

BACKGROUND OF INVENTION

[0002] Subtilisin enzymes usually refer to extracellular serine endopeptidases from related *Bacillus* species: for example subtilisin Carlsberg from *Bacillus licheniformis* (Jacobs et al., Nucleic Acids Res 13: 8913-8926, 1985); subtilisin BPN' from *Bacillus amyloliquifaciens* (Wells et al., Nucleic Acids Res 11: 7911-7925, 1983) and alkaline protease PB92 from *Bacillus alcalophilus* PB92 (Van Der Laan et al., Appl. Environ. Microbiol. 57, 901-909, 1991) etc. Subtilisin enzymes have been studied extensively in last decades because of their usefulness as additives to detergents, esp. to laundry detergents.

[0003] There are several advantages about these subtilisins mentioned above. They usually possess high efficiency and little specificity e.g. they can degrade almost all kinds of proteins. They can exhibit activity at high pH (pH 8-12) and in the presence of some surfactants. In addition they are extracellular enzymes secreted by the bacteria into the medium. Thus they can be isolated without breaking the bacterial cells, which makes the purification process easier and less costly.

[0004] To be suitable for use in detergents, proteases must exhibit the following properties:

- [0005] 1. They must possess broad substrate specificity;
- [0006] 2. They must have activity and stability at alkaline pH range.
- [0007] 3. They must be stable at high temperature and in the presence of chelating agents, perborates and surfactants.
- [0008] 4. They must be efficacious at low temperatures (20-40° C.).

[0009] However, the yield of subtilisin naturally secreted by *Bacillus* species is usually low and could not meet the requirement of industry. Fortunately, the application of genetic engineering has greatly enhanced its production yield (Jacobs et al., Gene 152: 69-74, 1995; Zaghloul et al., Enzyme Microb Technol 16: 534-537, 1994). Now subtilisins can be industrially produced. In this patent an expression system based on *Bacillus subtilis* was successfully used to produce subtilisins with high yield in a short period of time.

[0010] Enzyme Production by the Phase ϕ 105 Overexpression System

[0011] In a previously established ϕ 105 system (Thornewell et al., Gene 133:47-53, 1993), a defective

prophage vector, ϕ 105MU331 was derived for high-level protein overexpression expression in *B. subtilis* (Leung & Errington, Gene 154(1):1-6, 1995). In this derived system, not only efficient inducible (by heat) transcription of the gene is provided, but also, it prevented the lysis of the host cell. Thus the enzyme produced can be collected easily in the culture media without disruption of the cells, which means the purification steps can be greatly diminished. In addition to this, unlike *E. coli*, *Bacilli* are GRAS bacteria, the genes encoding their proteins are also GRAS to animals and thus, human.

SUMMARY OF THE INVENTION

[0012] The present invention provides genetically engineered *Bacillus* strains that can secrete large amount of *Bacillus* proteases in the extracellular culture medium. More particularly, this invention relates to a process of producing recombinant protease molecules of *Bacillus* origin in a *Bacillus subtilis* strain 168, utilizing a strong prophage promoter and a signal peptide from subtilisin E of the *Bacillus subtilis*.

[0013] Preferred molecules of the present invention include protease genes subtilisin Carlsberg, and subtilisin BPN' from *Bacillus licheniformis* (ATCC 10716) and *Bacillus amyloliquifaciens* (ATCC 23844), respectively.

[0014] It is another object of the present invention to provide a rapid process for producing large quantity of protease enzyme.

[0015] In accordance with one aspect of the present invention, there are provided protease enzymes for applications in commercial processes, such as, detergent applications.

[0016] In a further aspect of the present invention, there is provided a process for producing related proteases by recombinant technology comprising a *Bacillus* host and the strong prophage promoter described in this invention.

[0017] In this invention, an integration vector pSGE containing the DNA of the signal peptide of the subtilisin E gene from a *Bacillus subtilis* strain was constructed. Subtilisin E is a natural secretion protein of *Bacillus subtilis*. In our studies, the expression yields of the proteases subtilisin Carlsberg and subtilisin BPN' cloned from *Bacillus licheniformis*; (ATCC 10716) and *Bacillus amyloliquifaciens* (ATCC 23844) were greatly enhanced by replacing the native signal peptides of these proteases with that of the Subtilisin E. Since both target proteases were heterologous proteins to *Bacillus subtilis*, their signal peptides could not be properly processed by the secretory machinery of *B. subtilis*. By exchanging their signal peptides with that of the subtilisin E, this allowed proper secretion of these proteins.

[0018] The signal peptide DNA sequence from subtilisin E gene was first amplified by PCR and then cloned into the plasmid pSGT, which contains a terminator DNA from the α -amylase gene of *Bacillus licheniformis*. The plasmid containing signal peptide sequence of subtilisin E gene and terminator sequence of α -amylase gene was designated pSGE (FIG. 1).

[0019] Two alkaline protease genes, including subtilisin Carlsberg from *Bacillus licheniformis*; (ATCC 10716) and subtilisin BPN' from *Bacillus amyloliquifaciens* (ATCC 23844), were amplified and cloned into the integration

vector pSGE, to create pSG-C and pSG-B, respectively. Plasmids containing these protease genes were then transformed into *B. subtilis*. Then transformants were screened on milk plate. Some transformants that showed larger clear zones than negative control on milk plate were used to overproduce the target proteases.

[0020] The invention features nucleic acid molecules which are at least 45% (or 55%, 65%, 75%, 85%, 95%, 98% or 99%) identical to the nucleotide sequence of any of SEQ ID 7, 9, 14, or a complement thereof.

[0021] The invention features nucleic acid molecules which are at least 45% (or 55%, 65%, 75%, 85%, 95%, or 98%) identical to the nucleotide sequence of any of SEQ ID 7, 9, or 14, or a complement thereof, wherein such nucleic acid molecules encode polypeptides or proteins that exhibit at least one structural and/or functional feature of a polypeptide of the invention.

[0022] The invention features nucleic acid molecules of at least 200, 250, 300, 350, 400, 450, 500, 550, 575, 600, 625, 650, 675, 700, 725, 750, 800, 850, 900, 950, 1000, 1050, 1100, 1125 or 1149 nucleotides of the nucleotide sequence of SEQ ID NO: 7.

[0023] The invention features nucleic acid molecules which include a fragment of at least 200, 250, 300, 350, 400, 450, 500, 550, 575, 600, 625, 650, 675, 700, 725, 750, 800, 850, 900, 950, 1000, 1050, 1100, 1125 or 1140 nucleotides of the nucleotide sequence of SEQ ID NO: 9, or a complement thereof.

[0024] The invention features nucleic acid molecules of at least 250, 275, 300, 325, 350, 375, 400, 425, 450, or 479 nucleotides of the nucleotide sequence of SEQ ID NO: 14, or a complement thereof.

[0025] The invention also features nucleic acid molecules which include a nucleotide sequence encoding a protein having an amino acid sequence that is at least 45% (or 55%, 65%, 75%, 85%, 95%, 98%, or 99%) identical to the amino acid sequence of any of SEQ ID Nos: 8, 10, 11, or 12.

[0026] The invention also features nucleic acid molecules which include a nucleotide sequence encoding a protein having an amino acid sequence that is at least 45% (or 55%, 65%, 75%, 85%, 95%, 98%, or 99%) identical to the amino acid sequence of any of SEQ ID Nos: 8, 10, 11, or 12, wherein the protein encoded by the nucleotide sequence also exhibits at least one structural and/or functional feature of a polypeptide of the invention.

[0027] Also within the invention are nucleic acid molecules which encode a fragment of a polypeptide having the amino acid sequence of any of SEQ ID Nos: 8, 10, 11, or 12, the fragment including at least 15 (20, 25, 30, 35, 40, 45, 50, 55, 60, 65, 70, 75, 80, 85, 90, 95, 100, 110, 120, 130, 140, 150, 160, 170, 180, 190, 200, 210, 220, 230, 240, 250, 260, 270, 280, 290, 300, 310, 320, 330, 340, 350, 360, 370, 380, 381 or 382) contiguous amino acids of any of SEQ ID Nos: 8, 10, 11, or 12.

[0028] Also within the invention are nucleic acid molecules which encode a fragment of a polypeptide having the amino acid sequence of any of SEQ ID Nos: 8, 10, 11, or 12, the fragment including at least 15 (20, 25, 30, 35, 40, 45, 50, 55, 60, 65, 70, 75, 80, 85, 90, 95, 100, 110, 120, 130, 140, 150, 160, 170, 180, 190, 200, 210, 220, 230, 240, 250, 260,

270, 280, 290, 300, 310, 320, 330, 340, 350, 360, 370, 380, 381 or 382) contiguous amino acids of any of SEQ ID Nos: 8, 10, 11, or 12, wherein the fragment exhibits at least one structural and/or functional feature of a polypeptide of the invention.

[0029] The invention includes nucleic acid molecules which encode a naturally occurring allelic variant of a polypeptide comprising the amino acid sequence of any of SEQ ID Nos: 8, 10, 11, or 12, wherein the nucleic acid molecule hybridizes under stringent conditions to a nucleic acid molecule having a nucleic acid sequence encoding any of SEQ ID Nos: 8, 10, 11, or 12, or a complement thereof.

[0030] The invention includes nucleic acid molecules which encode a naturally occurring allelic variant of a polypeptide comprising the amino acid sequence of any of SEQ ID Nos: 8, 10, 11, or 12, wherein the nucleic acid molecule hybridizes under stringent conditions to a nucleic acid molecule having a nucleic acid sequence encoding any of SEQ ID Nos: 8, 10, 11, or 12, or a complement thereof, wherein such nucleic acid molecules encode polypeptides or proteins that exhibit at least one structural and/or functional feature of a polypeptide of the invention.

[0031] Also within the invention are isolated polypeptides or proteins having an amino acid sequence that is at least about 65%, preferably 75%, 85%, 95%, 98%, or 99% identical to the amino acid sequence of any of SEQ ID Nos: 8, 10, 11, or 12.

[0032] Also within the invention are isolated polypeptides or proteins having an amino acid sequence that is at least about 65%, preferably 75%, 85%, 95%, or 98% identical to the amino acid sequence of any of SEQ ID Nos: 8, 10, 11, or 12, wherein the polypeptides or proteins also exhibit at least one structural and/or functional feature of a polypeptide of the invention.

[0033] Also within the invention are polypeptides which are naturally occurring allelic variants of a polypeptide that includes the amino acid sequence of any of SEQ ID Nos: 8, 10, 11, or 12, wherein the polypeptide is encoded by a nucleic acid molecule which hybridizes under stringent conditions to a nucleic acid molecule having the sequence of any of SEQ ID Nos: 7, 9, or a complement thereof.

[0034] Also within the invention are polypeptides which are naturally occurring allelic variants of a polypeptide that includes the amino acid sequence of any of SEQ ID Nos: 8, 10, 11, or 12, wherein the polypeptide is encoded by a nucleic acid molecule which hybridizes under stringent conditions to a nucleic acid molecule having the sequence of any of SEQ ID Nos: 7 or 9, or a complement thereof, wherein such nucleic acid molecules encode polypeptides or proteins that exhibit at least one structural and/or functional feature of a polypeptide of the invention.

[0035] In yet another embodiment, a method is provided for producing a polypeptide, comprising:

[0036] (a) cultivating a *Bacillus* cell in a medium conducive for the production of a polypeptide, wherein the *Bacillus* cell comprises a nucleic acid construct comprising a Φ 105MU331 promoter in which the Φ 105MU331 promoter sequence is operably linked to a nucleic acid sequence encoding the polypeptide; and

[0037] (b) isolating the polypeptide from the cultivation medium.

[0038] In yet another embodiment of the above recited method, the nucleic acid sequence encodes a protease subtilisin gene product, Carlsberg, cloned from a *Bacillus licheniformis* strain (ATCC No. 10716), the protease subtilisin BPN' gene product from *Bacillus amyloliquifaciens* (ATCC No. 23844), or a combination thereof.

[0039] In yet another embodiment of the above recited method, the nucleic acid sequence encodes a protease subtilisin gene product coding sequence, Carlsberg, cloned from a *Bacillus licheniformis* strain (ATCC No.10716)(SEQ ID NO: 7), the protease subtilisin BPN' gene from *Bacillus amyloliquifaciens* (SEQ ID NO: 9)(ATCC No. 23844), or a combination thereof.

[0040] In yet another embodiment of the above recited method, the nucleic acid sequence encodes a protease subtilisin gene product coding sequence, Carlsberg, cloned from a *Bacillus licheniformis* strain (ATCC No. 10716)(SEQ ID NO: 7), or the protease subtilisin BPN' gene from *Bacillus amyloliquifaciens* (SEQ ID NO 9)(ATCC No.23844) operably linked to the 30 amino acid signal peptide of *B. subtilis* 168 subtilisin E.

[0041] In yet another embodiment of the above recited method, the nucleic acid construct further comprises a selectable marker gene.

[0042] In yet another embodiment of the above recited method, the selectable marker is the CAT gene.

[0043] In yet another embodiment of the above recited method, the *Bacillus* cell contains no selectable marker gene.

[0044] In yet another embodiment of the above recited method, the nucleic acid sequence encodes a polypeptide heterologous to the *Bacillus* cell.

[0045] In yet another embodiment of the above recited method, the polypeptide is a hormone or variant thereof, enzyme, receptor or portion thereof, antibody or portion thereof, or reporter.

[0046] In yet another embodiment of the above recited method, the enzyme is an aminopeptidase, amylase, carbohydrase, carboxypeptidase, catalase, cellulase, chitinase, cutinase, cyclodextrin glycosyltransferase, deoxyribonuclease, esterase, alpha-galactosidase, beta-galactosidase, glucoamylase, alpha-glucosidase, beta-glucosidase, invertase, laccase, lipase, mannosidase, mutanase, oxidase, pectinolytic enzyme, peroxidase, phytase, polyphenoloxidase, proteolytic enzyme, ribonuclease, transglutaminase, or xylanase.

[0047] In yet another embodiment of the above recited method, the *Bacillus* host cell is a *Bacillus alkalophilus*, *Bacillus amyloliquifaciens*, *Bacillus brevis*, *Bacillus circulans*, *Bacillus clausii*, *Bacillus coagulans*, *Bacillus firmus*, *Bacillus lautus*, *Bacillus lentus*, *Bacillus licheniformis*, *Bacillus megaterium*, *Bacillus pumilus*, *Bacillus stearothermophilus*, *Bacillus subtilis*, *Bacillus thuringiensis*, *Bacillus thermoleovorans* strain (ATCC No. 43506), *Bacillus subtilis* strain 168, or *Bacillus subtilis* strain MU331.

[0048] In yet another embodiment of the above recited method, the nucleic acid sequence encodes a polypeptide homologous to the *Bacillus* cell.

[0049] In yet another embodiment of the above recited method, the polypeptide is a protease.

[0050] In yet another embodiment of the above recited method, the *Bacillus* cell is a *Bacillus amyloliquifaciens* cell.

[0051] In yet another embodiment of the above recited method, the *Bacillus* cell is a *Bacillus licheniformis* cell.

FIGURE LEGENDS

[0052] The following figures illustrate the embodiments of the invention and are not meant to limit the scope of the invention encompassed by the claims.

[0053] **FIG. 1.** (A) Schematic map of the expression vector pSGt. Heterologous gene(s) is inserted into the multicloning sites (MCS) of the vector. The vector carries a pBR 322 replication origin (ORF) for *E. coli*, the promoter and the ribosome binding site of the ORF 19 of the bacteriophage phi-105 (Φ -105), the terminator of *B. licheniformis* α -amylase (term), a cat gene for chloramphenicol resistance and a bla gene for ampicillin resistance. (B) Schematic maps of the expression vectors pSG-E, pSG-C and pSG-B.

[0054] **Fig.2.** The amino acid sequences of the subtilisin E-protease fusion proteins. Amino acid residues representing the signal peptide of *B. subtilis* subtilisin E were shown in Italics. The DNA sequences encoding the mature proteases subtilisin Carlsberg and subtilisin BPN' were cloned in frame with the signal peptide of *B. subtilis* subtilisin E. The amino acid residues determined by N-terminal protein sequencing were underlined.

[0055] **FIG. 3.** Overexpression of the recombinant proteases in shaking flasks using various media. (A) Overexpression of protease BPN'. (B) Overexpression of protease Carlsberg. At 4 hours after heat induction, 10 μ l culture supernatants were run into each lane. Protein markers were loaded on the first lane on the left. CP: 100 μ g commercial enzyme powder concentrate from NovoNordis (Savinase 4.0T).

[0056] **FIG. 4.** Overexpression of the recombinant proteases in a 2L fermentor. (A) Overexpression of protease BPN'. (B) Overexpression of protease Carlsberg. Protein markers were loaded on the first lane on the left. CP: 100 μ g commercial enzyme powder concentrate from NovoNordis (Savinase 4.0T).

[0057] **FIG. 5.** Thermal stability test.

[0058] **FIG. 6.** Overexpression of protease BPN' using a medium rich in soybean meal (SBM). 10 μ l supernatants were run into each lane. CP: 100 μ g commercial enzyme powder concentrate from NovoNordis (Savinase 4.0T).

EXAMPLES

[0059] 1. Amplification of Protease Genes from *B. subtilis* Strain 168, *Bacillus amyloliquifaciens* and *Bacillus licheniformis*

[0060] *Bacillus subtilis* 168, *Bacillus amyloliquifaciens* (ATCC 23844) and *Bacillus licheniformis* (ATCC 10716) were used as the source of chromosomal DNA. PCR was performed with three pairs of primer (Table 1). The first pair of primer, SubES (SEQ. ID No. 1) and SubEA (SEQ. ID No. 2) was used to amplify the signal peptide of the subtilisin E

gene from *Bacillus subtilis* 168. The other two pairs of primers, BPN'-S (SEQ. ID No. 3)/BPN'-A (SEQ. ID No. 4) and CAR-S (SEQ. ID No. 5)/CAR-A (SEQ. ID No. 6) were used to amplify the protease genes BPN' and Carlsberg from *B. licheniformis* and *B. amyloliquifaciens*, respectively. PCR was carried out for 30 cycles with each cycle composed of 4 min at 94° C. (denaturation), 40 second at 53° C. (annealing), 3 min at 75° C. (extension), Pfu polymerase was employed to safeguard the fidelity of the reaction. The DNA and its deduced amino acid sequences of protease BPN' are shown in SEQ. ID No. 7 and SEQ. ID No. 8, whereas those of the protease Carlsberg are shown in SEQ. ID No. 9 and SEQ. ID No. 10. It was expected that the signal peptides of the proteases from *B. licheniformis* and *B. amyloliquifaciens* might not be correctly processed in the expression host *B. subtilis*, therefore only the gene fragment encoding for the mature enzyme was amplified.

and screened by PCR. Positive clones were selected and grown in LB broth with ampicillin (100 µg/ml) overnight. The plasmids were extracted from the cells by using the Bio Rad Quantum prep Plasmid Miniprep kit, under the recommended conditions.

[0063] 3. Transformation of *Bacillus subtilis*

[0064] A *Bacillus* recipient strain (*B. subtilis* MU331) was streaked onto a LB-agar plate with erythromycin (5 µg/ml) and incubated at 37° C. overnight. Multiple colonies were inoculated into 5 ml pretransformation medium [(PTM)—2.2% (v/v) of 40% w/v glucose; 1% (v/v) solution P (0.5 ml of 0.1M CaCl₂·2H₂O, 2.5 ml of 1.0M MgSO₄·7H₂O, 0.01 ml of 1.0M MnSO₄·4H₂O and 7.0 ml ddH₂O); 1.8% (v/v) Casamino (2 g/L); 1% (v/v) Tryptophan (2 mg/ml); 1% (v/v) Isoleucine (20 mg/ml); 1% (v/v) Valine (20 mg/ml); 1% (v/v) Leucine (20 mg/ml); 1% (v/v) Methionine (5 mg/ml);

TABLE 1

Primers employed in this study			
Primer name	Sequence	Orientation	Template
SubES	gcgatcgCATATGAGAAGCAAAAATTTGTGGATCAGC	sense	Signal peptide for subtilisin E
SubEA	gcggatccCGGGCCGCCTGCGCAGACATGTTGC	antisense	Signal peptide for subtilisin E
BPN-S	gcgatatcGGGGCCGCAGGGAATCAAACGGGGAA	sense	Mature BPN gene
BPN-A	gcGGATCCACTTGGCCGTTACGGGACT	antisense	Mature BPN gene
CAL-S	gcgatatcCGGGCCGCCTCAACCGGCGAAAAATGTT	sense	Mature Calsberg gene
CAL-A	gcGGATCCTTATTGAGCGGCAGCTTCGAC	antisense	Mature Calsberg gene
phi-1-5	ATAGACAATCGCGGTTAAC	sense	phi-105 ORF19 promoter

[0061] 2. Construction of pSGt Expression Plasmids Carrying the Protease Genes

[0062] The PCR fragments were purified by phenol/chloroform extraction and ethanol precipitation. The DNA fragment obtained by the SubE primers, the BPN' primers and the CAR primers were subjected to Nde I/Bam HI, Not I/Bam HI and Not I/Bam HI restriction enzyme digestion, respectively. Since Subtilisin E is of *B. subtilis* origin, its native signal peptide was compatible to the expression host strain *B. subtilis*. Therefore, the coding sequence of its signal peptide was subcloned into the Nde I and Bam HI sites of the cloning vector pSGt (FIG. 1) to create pSG-E, in which a Not I site was engineered. On the other hand, since the signal peptides of the protease from *B. licheniformis* and *B. amyloliquifaciens* were not compatible to *B. subtilis*, only the coding sequences of the mature enzymes were cloned into the NotI/BamHI sites of the pSGE to create pSG-B and pSG-C. The map of these vectors is shown in FIG. 1B. The amino acid sequences of the resultant fusion proteins (SEQ. ID Nos. 11 and 12) were aligned in FIG. 2. After ligation overnight, the plasmids were ethanol precipitated before transformation into *E. coli*. Competent *E. coli* cells (Top 10) were prepared and transformed by electroporation with the Bio Rad pulser under the conditions recommended by the supplier. The electroporated cells were transferred to 2× YT and incubated at 37° C. for 40 minutes before spreading onto LB-agar plates with ampicillin (100 µg/ml). After overnight incubation, colonies were picked from the LA-agar plates

90% (v/v) of Spizizen minimal medium (0.2% (w/v) ammonium sulphate, 1.4% (w/v) dipotassium phosphate, 0.6% (w/v) potassium dihydrogen phosphate, 0.1% (w/v) sodium citrate dihydrate, 0.02% (w/v) magnesium sulphate)], and incubated at 37° C. with shaking at 280 rpm. Cell growth was monitored, until OD₆₀₀ reached 3.0~3.3.

[0065] 100 µl of competent cells were mixed with about 2 µg DNA and transferred into 1 ml pre-warmed (37° C.) transformation medium [(TM)—1.4% (v/v) of 40% (w/v) glucose; 0.47% (v/v) solution F (1.0M MgSO₄·7H₂O); 0.05% (v/v) Casamino (2 g/l); 0.93% (v/v) Tryptophan (2 mg/ml); 0.93% (v/v) Isoleucine (20 mg/ml); 0.93% (v/v) Valine (20 mg/ml); 0.93% (v/v) Leucine (20 mg/ml); 0.93% (v/v) Methionine (5 mg/ml); 93.4% (v/v) of Spizizen minimal medium (0.2% (w/v) ammonium sulphate, 1.4% (w/v) dipotassium phosphate, 0.6% (w/v) potassium dihydrogen phosphate, 0.1% (w/v) sodium citrate dihydrate, 0.02% (w/v) magnesium sulphate)] and incubated at 37° C. with shaking at 280 rpm for 1.5 hour. The culture was centrifuged (13,200 rpm, 2 min) and 150 µl was spread onto LB-agar plates with chloramphenicol (5 µg/ml). The plates were incubated at 37 overnight and each single colony was transferred onto a LB-agar plate with erythromycin (5 µg/ml) and one with chloramphenicol (5 µg/ml) on the next day. PCR screening was performed on the colonies by using a promoter specific primer, phi-105, (SEQ. ID No. 13) and one of the protease specific antisense primers.

[0066] 4. Overexpression of Proteases in *B. subtilis* MU331

[0067] Bacterial cells from frozen stock was streaked onto LB-agar plate with chloramphenicol (5 µg/ml) and incubated at 37° C. overnight. A single colony was inoculated into 15 ml BHY medium (3.7% (w/v) brain-heart infusion broth, 0.5% (w/v) yeast extract) with chloramphenicol (5 µg/ml) and incubated at 37° C. with shaking at 270 rpm overnight. 12 ml of the overnight culture was transferred into 100 ml BHY medium without chloramphenicol, and incubated at 37° C. with shaking at 280 rpm. Cell growth was monitored by reading OD₆₀₀ until it reached 5.3-5.9. Heat shock was then performed by placing the sample in a 50° C. water-bath for 8 minutes with vigorous shaking and then re-incubated at 37° C., with shaking at 280 rpm. At 4 hours post-induction, all samples were collected and centrifuged to remove cell pellets.

[0068] 5. N-terminal Amino Acid Sequence Analysis

[0069] N-terminal amino acid sequence analysis was performed after protein separation by SDS/PAGE and transferred to PVDF membrane. The band of interest was cut out and subjected to automated Edman degradation with the Hewlett Packard protein sequencer (model G1000A), in accordance with the manufacturer's instruction. Analysis of the N-terminal sequence of the mature protease A shows that the signal peptides and the propeptides of the proteases were correctly cleaved. The first seven amino acid residues of the mature protease Carlsberg and BPN' were AQTVPYG and AQSVPYG, respectively. As a result, both mature proteases had 275 amino acid residues.

[0070] 6. Protease Activity Assay Using succinyl-Ala-Ala-Pro-Phe-p-nitroanilide (SucAAPF-pNA) Mitchinson and Wells, Biochemistry 28: 4807-4815, 1989)

[0071] A synthetic substrate succinyl-Ala-Ala-Pro-Phe-p-nitroanilide (SucAAPF-pNA) was employed for protease activity enzyme. The colourless substrate can be converted into a yellowish product, p-nitroanilide (pNA), by protease activity. A 0.5 mM stock of SucAAPF-pNA was prepared in a 0.1 M Tris-HCl buffer, pH 8.6 and the enzyme-containing culture supernatants were diluted in the same buffer. 10 µl diluted enzyme was then mixed with 190 µl substrate in triplicate into the wells of a 96 well ELISA plate and incubated at 22° C. A blank was prepared by mixing 10 µl Tris-HCl buffer with 190 µl substrate. OD reading at 405 nm was taken at 20 mins and 30 mins, respectively. To prepare a standard curve, a 1 mM p-nitroaniline (pNA) stock was serially diluted and OD₄₀₅ readings were measured. One enzyme unit (EU) is defined as the amount of enzyme that releases 1 micromole of pNA per minute at 22° C.

[0072] 7. Protease Activity Assay Using Azocoll as Substrates (Chavira, et al., Anal Biochem 136: 446-450 1984)

[0073] 50 mM Tris-HCl containing 5 mM calcium chloride at pH 8.0 was used as the assay buffer. 150 mg Azocoll was first stirred in 30 ml of assay buffer for 2 hours before filtered through a Whatman No. 1 filter paper to remove the filtrate. The undissolved pellet was resuspended in 30 ml assay buffer and 1 ml aliquots were made. Protease in the culture supernatant was diluted 50 times in the assay buffer and 20 µl diluted enzyme is added to 1 ml Azocoll suspension which has been preheated at 37° C. After incubating the mixture at 37° C. for 1 hour, the reaction was stopped on ice bath and unhydrolysed azocoll was removed by centrifugation at 10000 g for 5 min. The color of the supernatant was

measured at OD₅₂₀nm. One enzyme unit (EU) is defined as the amount of enzyme that produces an OD₅₂₀ nm of 0.5.

[0074] 8. Overexpression of the Proteases in Shake Flasks Using Industrial Media

[0075] Five media were formulated by industrial grade chemicals and their ability to support protease overexpression was examined. The formulations are shown in Table 2. A single colony was inoculated into 15 ml BHY medium (3.7% (w/v) brain-heart infusion broth, 0.5% (w/v) yeast extract) with chloramphenicol (5 µg/ml) and incubated at 37° C. with shaking at 270 rpm overnight. 1 ml of the overnight culture was transferred into 20 ml formulated media without chloramphenicol, and incubated at 37° C. with shaking at 280 rpm. Heat shock was then performed at 4 hours post-inoculation by placing the flasks in a 50° C. water-bath for 5 minutes with vigorous shaking and then re-incubated at 37° C., with shaking at 280 rpm. At 4 hours post-induction, all samples were collected and centrifuged to remove cell pellets and 20 µl supernatant collected was subjected to SDS/PAGE. The overexpression of protease Carlsberg and BPN' in various media were shown in FIGS. 3A and 3B, respectively. The enzyme activities were shown in Table 3.

TABLE 2

Formulations of various media			
Medium A3	g/liter	Medium B2	g/liter
Malto-dextrin	50	Malto-dextrin	50
NH ₄ NO ₃	4	NH ₄ NO ₃	4
Hydrolyzated soybean protein	6	Yeast extract	10
Medium E1	g/liter	Medium E2	g/liter
Hydrolyzated soybean protein	25	Hydrolyzated soybean protein	40
CaCO ₃	5	CaCO ₃	5
Potato Starch	5	Potato Starch	5
Medium N5	g/liter		
Glucose	50		
NaHCO ₃	5		
(NH ₄) ₂ HPO ₄	2.5		
Yeast extract	10		

[0076]

TABLE 3

Enzyme activities of proteases Carlsberg and BPN' expressed in various media.								
Pro-teases	Substrates	BHY	A3	B2	E1	E2	N5	CP
Carls-berg	sAAPF-pNA	50.95	18.39	28.12	43.25	44.77	17.77	0.98
BPN'	sAAPF-pNA	5.70	3.23	5.26	2.32	1.41	3.27	0.98
Carls-berg	Azocoll	1176	404	604	950	985	391	180
BPN'	Azocoll	866	508	804	324	200	520	180

[0077] The enzyme activities are expressed in U/ml for the media BHY, A3, B2, E1, E2 and N5. For CP, a protease powder concentrate (Savinase 4.0T) from NovoNordis, the enzyme unit is expressed in U/mg.

[0078] 9. Overexpression of Proteases BPN' and Carlsberg in Fermentor

[0079] A fresh bacillus colony was inoculated into 80 ml BHY medium with chloramphenicol and the seed culture was shaken at 37° C. at 280 rpm. After overnight incubation, 80 ml seed culture was inoculated into 1.6 L BHY medium without chloramphenicol in a 2 litre fermentor (Biostat B, B. Bruan International). The temperature was controlled at 37° C. and the pH was controlled at 7.0 by addition of acid and base. Dissolved oxygen was maintained at 30% by a control loop that varied the stir speed. Heat induction was carried out when the OD reached 5.0 by increasing the temperature to 50° C. and then decreased to 37° C. immediately. Usually this heat induction process could be completed in 30 mins. Culture supernatants were recovered at 4 hours and 16 hours post-induction for enzyme activity assay and SDS-PAGE analysis. The results of SDS-PAGE were shown in FIG. 4. In general, higher yields of proteases were obtained from fermentor than from shaking flasks.

TABLE 4

Enzyme activities of proteases Carlsberg and BPN' produced in fermentor.					
Proteases	Substrates	Shake flask	4 hr post-induction	16 hr post-induction	CP
Carlsberg	sAAPF-pNA	40.1	81.4	124.39	0.98
Carlsberg	Azocoll	856	1756	2728	180
BPN'	sAAPF-pNA	2.62	5.32	6.46	0.98
BPN'	Azocoll	514	954	1358	180

[0080] The enzyme activities are expressed in U/ml of culture supernatant. For CP, a protease powder concentrate (Savinase 4.0T) from NovoNordis, the enzyme unit is expressed in U/mg.

[0081] 10. Thermal Stability of the Proteases

[0082] The thermal stability of the expressed proteases Carlsberg and BPN' was compared with a commercial protease (Savinase 4.0T). The protease solutions were first incubated at room temperature, 40° C., 50° C., 60° C., 70° C and 80° C. for 20 min down on ice. Afterwards, the protease solutions were equilibrated to room temperature and a protease activity assay using SucAAPF-pNA as substrate was carried out. As shown in FIG. 5, the protease BPN' and the commercial protease have better thermal stability than the protease Carlsberg.

[0083] 11. Overexpression of Protease BPN' Using a Medium Rich in Soybean Meal

[0084] The ability of soybean meal to support the expression of protease BPN' was investigated by the procedures

described in Example 7. Media were prepared with increasing amount of soybean meal, from 25 g to 100 g per litre, and their ability to support protease overexpression were examined in shake flask. At 4 hours post-induction, all samples were collected and 10 µl supernatant was analyzed by SDS/PAGE (FIG. 6). The enzyme activities are shown in table 5.

Media ingredients:	
Medium SBM	g/liter
Soybean Meal	25-100
CaCO ₃	5
Potato Starch	5

[0085]

TABLE 5

Enzyme activities of proteases BPN' expressed in various media.								
Proteases	Substrates	BHY	B2	E1	SBM25 g	SBM50 g	SBM100 g	CP
BPN'	sAAPF-pNA	9.51	5.29	5.22	2.80	8.42	32.09	0.82

[0086] The enzyme activities are expressed in U/ml of culture supernatant. For CP, a protease powder concentrate (Savinase 4.0T), the enzyme unit is expressed in U/mg.

[0087] Equivalents

[0088] It will be appreciated that the various features described herein may be used singly or in any combination thereof. Therefore, the present invention is not limited to only the embodiments specifically described herein. While the foregoing description and drawings represent a preferred embodiment of the present invention, it will be understood that various additions, modifications, and substitutions may be made therein without departing from the spirit and scope of the present invention as defined in the accompanying claims. In particular, it will be clear to those skilled in the art that the present invention may be embodied in other specific forms, structures, arrangements, proportions, and with other elements, materials, and components, without departing from the spirit or essential characteristics thereof. One skilled in the art will appreciate that the invention may be used with many modifications of structure, arrangement, proportions, materials, and components and otherwise, used in the practice of the invention, which are particularly adapted to specific environments and operative requirements without departing from the principles of the present invention. The presently disclosed embodiment is therefore to be considered in all respects as illustrative and not restrictive, the scope of the invention being indicated by the appended claims, and not limited to the foregoing description.

SEQUENCE LISTING

<160> NUMBER OF SEQ ID NOS: 15

<210> SEQ ID NO 1
<211> LENGTH: 37
<212> TYPE: DNA
<213> ORGANISM: Artificial Sequence
<220> FEATURE:
<223> OTHER INFORMATION: Primer

<400> SEQUENCE: 1

gcgatcgcat atgagaagca aaaaattgtg gatcagc 37

<210> SEQ ID NO 2
<211> LENGTH: 33
<212> TYPE: DNA
<213> ORGANISM: Artificial Sequence
<220> FEATURE:
<223> OTHER INFORMATION: Primer

<400> SEQUENCE: 2

gcggatccgc ggccgcctgc gcagacatgt tgc 33

<210> SEQ ID NO 3
<211> LENGTH: 35
<212> TYPE: DNA
<213> ORGANISM: Artificial Sequence
<220> FEATURE:
<223> OTHER INFORMATION: Primer

<400> SEQUENCE: 3

gcgatatcgc ggccgcaggg aatcaaacg gggaa 35

<210> SEQ ID NO 4
<211> LENGTH: 27
<212> TYPE: DNA
<213> ORGANISM: Artificial Sequence
<220> FEATURE:
<223> OTHER INFORMATION: Primer

<400> SEQUENCE: 4

gcggatccac ttggccgtta cgggact 27

<210> SEQ ID NO 5
<211> LENGTH: 35
<212> TYPE: DNA
<213> ORGANISM: Artificial Sequence
<220> FEATURE:
<223> OTHER INFORMATION: Primer

<400> SEQUENCE: 5

gcgatatcgc ggccgctcaa ccggcgaaaa atggt 35

<210> SEQ ID NO 6
<211> LENGTH: 29
<212> TYPE: DNA
<213> ORGANISM: Artificial Sequence
<220> FEATURE:
<223> OTHER INFORMATION: Primer

<400> SEQUENCE: 6

gcggatcctt attgagcggc agcttcgac 29

-continued

```

<210> SEQ ID NO 7
<211> LENGTH: 1149
<212> TYPE: DNA
<213> ORGANISM: Bacillus amyloliquifaciens

<400> SEQUENCE: 7

gtgagaggca aaaaagtatg gatcagtttg ctgtttgctt tagcgtaat ctttacgatg    60
gogttcggca gcacatcctc tgcccaggcg gcagggaaat caaacgggga aaagaaatat    120
attgtcgggt ttaaacagac aatgagcacg atgagcgccg ctaagaagaa agatgtcatt    180
tctgaaaaag gcgggaaagt gcaaaagcaa tcaaatatg tagacgcagc ttcagctaca    240
ttaaacgaaa aagctgtaaa agaattgaaa aaagaccgga gcgtcgctta cgttgaagaa    300
gatcacgtag cacatgcgta cgcgcagtcc gtgccttacg gcgtatcaca aattaaagcc    360
cctgctctgc actctcaagg ctacactgga tcaaatgtaa aagtagcggg tatcgacagc    420
ggtatcgatt cttctcatcc tgatttaaag gtagcaggcg gagccagcat ggttccttct    480
gaaacaaatc ctttccaaga caacaactct cacggaactc acgttgoccg cacagttgcg    540
gctcttaata actcaatcgg tgtattagcg gttgcgcaa gcgcatcact ttacgctgta    600
aaagttctcg gtgctgacgg ttcccgccaa tacagctgga tcattaacgg aatcgagtgg    660
gcgatcgcaa acaaatatgga cgttattaac atgagcctcg gcggaccttc tggttctgct    720
gctttaaagc cggcagttga taaagcgtt gcatccggcg tcgtagtcgt tcgcgagcgc    780
ggtaacgaag gcacttccgg cagctcaagc acagtgggct accctggtaa atacccttct    840
gtcattgcag taggcgctgt tgacagcagc aaccaagag catctttctc aagcgttaga    900
cctgagcttg atgtcatggc acctggcgta tctatccaaa gcacgcttcc tggaaacaaa    960
tacggggcgt acaacgggtac gtcaatggca tctccgcacg ttgccggagc ggctgctttg   1020
attctttcta agcaccgaa ctggacaaac actcaagtcc gcagcagttt agaaaacacc   1080
actacaaaac ttggtgattc tttctactat ggaaaagggc tgatcaacgt acaggcggca   1140
gctcagtaa                                     1149
    
```

```

<210> SEQ ID NO 8
<211> LENGTH: 382
<212> TYPE: PRT
<213> ORGANISM: Bacillus amyloliquifaciens

<400> SEQUENCE: 8

Val Arg Gly Lys Lys Val Trp Ile Ser Leu Leu Phe Ala Leu Ala Leu
 1           5           10          15
Ile Phe Thr Met Ala Phe Gly Ser Thr Ser Ser Ala Gln Ala Ala Gly
          20          25          30
Lys Ser Asn Gly Glu Lys Lys Tyr Ile Val Gly Phe Lys Gln Thr Met
          35          40          45
Ser Thr Met Ser Ala Ala Lys Lys Lys Asp Val Ile Ser Glu Lys Gly
          50          55          60
Gly Lys Val Gln Lys Gln Phe Lys Tyr Val Asp Ala Ala Ser Ala Thr
          65          70          75          80
Leu Asn Glu Lys Ala Val Lys Glu Leu Lys Lys Asp Pro Ser Val Ala
          85          90          95
Tyr Val Glu Glu Asp His Val Ala His Ala Tyr Ala Gln Ser Val Pro
          100         105         110
    
```

-continued

Tyr Gly Val Ser Gln Ile Lys Ala Pro Ala Leu His Ser Gln Gly Tyr
 115 120 125
 Thr Gly Ser Asn Val Lys Val Ala Val Ile Asp Ser Gly Ile Asp Ser
 130 135 140
 Ser His Pro Asp Leu Lys Val Ala Gly Gly Ala Ser Met Val Pro Ser
 145 150 155 160
 Glu Thr Asn Pro Phe Gln Asp Asn Asn Ser His Gly Thr His Val Ala
 165 170 175
 Gly Thr Val Ala Ala Leu Asn Asn Ser Ile Gly Val Leu Gly Val Ala
 180 185 190
 Pro Ser Ala Ser Leu Tyr Ala Val Lys Val Leu Gly Ala Asp Gly Ser
 195 200 205
 Gly Gln Tyr Ser Trp Ile Ile Asn Gly Ile Glu Trp Ala Ile Ala Asn
 210 215 220
 Asn Met Asp Val Ile Asn Met Ser Leu Gly Gly Pro Ser Gly Ser Ala
 225 230 235 240
 Ala Leu Lys Ala Ala Val Asp Lys Ala Val Ala Ser Gly Val Val Val
 245 250 255
 Val Ala Ala Ala Gly Asn Glu Gly Thr Ser Gly Ser Ser Ser Thr Val
 260 265 270
 Gly Tyr Pro Gly Lys Tyr Pro Ser Val Ile Ala Val Gly Ala Val Asp
 275 280 285
 Ser Ser Asn Gln Arg Ala Ser Phe Ser Ser Val Gly Pro Glu Leu Asp
 290 295 300
 Val Met Ala Pro Gly Val Ser Ile Gln Ser Thr Leu Pro Gly Asn Lys
 305 310 315
 Tyr Gly Ala Tyr Asn Gly Thr Ser Met Ala Ser Pro His Val Ala Gly
 325 330 335
 Ala Ala Ala Leu Ile Leu Ser Lys His Pro Asn Trp Thr Asn Thr Gln
 340 345 350
 Val Arg Ser Ser Leu Glu Asn Thr Thr Lys Leu Gly Asp Ser Phe
 355 360 365
 Tyr Tyr Gly Lys Gly Leu Ile Asn Val Gln Ala Ala Gln
 370 375 380

<210> SEQ ID NO 9

<211> LENGTH: 1140

<212> TYPE: DNA

<213> ORGANISM: Bacillus licheniformis

<400> SEQUENCE: 9

```

atgatgagga aaaagagttt ttggcttggg atgctgacgg ccttcattgct cgtgttcacg    60
atggcattca gcgattccgc ttctgctgct caaccggcga aaaatgttga aaaggattat    120
attgtcggat ttaagtccagg agtgaaaacc gcatctgtca aaaaggacat catcaaagag    180
agcggcggaa aagtggacaa gcagtttaga atcatcaacg cggcaaaagc gaagctagac    240
aaagaagcgc ttaaggaagt caaaaatgat ccggatgtcg cttatgtgga agaggatcat    300
gtggcccatg ccttggcgca aaccgttcct tacggcattc ctctcattaa agcggacaaa    360
gtgcaggctc aaggctttaa gggagcgaat gtaaaagtag ccgtcctgga tacaggaatc    420
caagcttctc atccggactt gaacgtagtc ggcggagcaa gctttgtggc tggcgaagct    480

```

-continued

```

tataacaccg acggcaacgg acacggcaca catggtgccg gtacagtagc tgcgcttgac 540
aatacaacgg gtgtattagg cggttgcgca agcgtatcct tgtacgcggt taaagtactg 600
aattcaacgg gaagcggaac ttacagcggc attgtaagcg gaatcgagtg ggcgacgaca 660
aacggcatgg atgttatcaa catgagtctt ggaggacat caggctcaac agcgatgaaa 720
caggcggttg acaatgcata tgcaagaggg gttgtcgttg tggcggtgc tgggaacagc 780
ggatcttcag gaaacacgaa tacaatcggc tatcctgcga aatacgactc tgtcatcgca 840
gttggcgctg tagactctaa cagcaacaga gcttcatttt ccagcgtcgg agcagagctt 900
gaagtcatgg ctctgtggcg aggcgtgtac agcacttacc caaccagcac ttaatgcaaca 960
ttgaacggaa cgtcaatggc ttctctcat gtagcgggag cagcagcttt gatcttgtca 1020
aaacatccga acctttcagc ttcacaagtc cgcaaccgtc tctccagtac ggcgacttat 1080
ttgggaagct ccttctacta tggaaaaggt ctgatcaatg tcgaagctgc cgctcaataa 1140

```

<210> SEQ ID NO 10

<211> LENGTH: 379

<212> TYPE: PRT

<213> ORGANISM: Bacillus licheniformis

<400> SEQUENCE: 10

```

Met Met Arg Lys Lys Ser Phe Trp Leu Gly Met Leu Thr Ala Phe Met
 1           5           10           15
Leu Val Phe Thr Met Ala Phe Ser Asp Ser Ala Ser Ala Ala Gln Pro
          20           25           30
Ala Lys Asn Val Glu Lys Asp Tyr Ile Val Gly Phe Lys Ser Gly Val
          35           40           45
Lys Thr Ala Ser Val Lys Lys Asp Ile Ile Lys Glu Ser Gly Gly Lys
          50           55           60
Val Asp Lys Gln Phe Arg Ile Ile Asn Ala Ala Lys Ala Lys Leu Asp
          65           70           75           80
Lys Glu Ala Leu Lys Glu Val Lys Asn Asp Pro Asp Val Ala Tyr Val
          85           90           95
Glu Glu Asp His Val Ala His Ala Leu Ala Gln Thr Val Pro Tyr Gly
          100          105          110
Ile Pro Leu Ile Lys Ala Asp Lys Val Gln Ala Gln Gly Phe Lys Gly
          115          120          125
Ala Asn Val Lys Val Ala Val Leu Asp Thr Gly Ile Gln Ala Ser His
          130          135          140
Pro Asp Leu Asn Val Val Gly Gly Ala Ser Phe Val Ala Gly Glu Ala
          145          150          155          160
Tyr Asn Thr Asp Gly Asn Gly His Gly Thr His Val Ala Gly Thr Val
          165          170          175
Ala Ala Leu Asp Asn Thr Thr Gly Val Leu Gly Val Ala Pro Ser Val
          180          185          190
Ser Leu Tyr Ala Val Lys Val Leu Asn Ser Ser Gly Ser Gly Thr Tyr
          195          200          205
Ser Gly Ile Val Ser Gly Ile Glu Trp Ala Thr Thr Asn Gly Met Asp
          210          215          220
Val Ile Asn Met Ser Leu Gly Gly Pro Ser Gly Ser Thr Ala Met Lys
          225          230          235          240
Gln Ala Val Asp Asn Ala Tyr Ala Arg Gly Val Val Val Val Ala Ala

```

-continued

Gly Gln Tyr Ser Trp Ile Ile Asn Gly Ile Glu Trp Ala Ile Ala Asn
 210 215 220

Asn Met Asp Val Ile Asn Met Ser Leu Gly Gly Pro Ser Gly Ser Ala
 225 230 235 240

Ala Leu Lys Ala Ala Val Asp Lys Ala Val Ala Ser Gly Val Val Val
 245 250 255

Val Ala Ala Ala Gly Asn Glu Gly Thr Ser Gly Ser Ser Ser Thr Val
 260 265 270

Gly Tyr Pro Gly Lys Tyr Pro Ser Val Ile Ala Val Gly Ala Val Asp
 275 280 285

Ser Ser Asn Gln Arg Ala Ser Phe Ser Ser Val Gly Pro Glu Leu Asp
 290 295 300

Val Met Ala Pro Gly Val Ser Ile Gln Ser Thr Leu Pro Gly Asn Lys
 305 310 315 320

Tyr Gly Ala Tyr Asn Gly Thr Ser Met Ala Ser Pro His Val Ala Gly
 325 330 335

Ala Ala Ala Leu Ile Leu Ser Lys His Pro Asn Trp Thr Asn Thr Gln
 340 345 350

Val Arg Ser Ser Leu Glu Asn Thr Thr Thr Lys Leu Gly Asp Ser Phe
 355 360 365

Tyr Tyr Gly Lys Gly Leu Ile Asn Val Gln Ala Ala Ala Gln
 370 375 380

<210> SEQ ID NO 12
 <211> LENGTH: 380
 <212> TYPE: PRT
 <213> ORGANISM: Artificial Sequence
 <220> FEATURE:
 <223> OTHER INFORMATION: Fusion protein between the signal peptide from
 B. subtilis and Carlsberg protease from B.licheniformis

<400> SEQUENCE: 12

Met Arg Ser Lys Lys Leu Trp Ile Ser Leu Leu Phe Ala Leu Thr Leu
 1 5 10 15

Ile Phe Thr Met Ala Phe Ser Asn Met Ser Ala Gln Ala Ala Ala Gln
 20 25 30

Pro Ala Lys Asn Val Glu Lys Asp Tyr Ile Val Gly Phe Lys Ser Gly
 35 40 45

Val Lys Thr Ala Ser Val Lys Lys Asp Ile Ile Lys Glu Ser Gly Gly
 50 55 60

Lys Val Asp Lys Gln Phe Arg Ile Ile Asn Ala Ala Lys Ala Lys Leu
 65 70 75 80

Asp Lys Glu Ala Leu Lys Glu Val Lys Asn Asp Pro Asp Val Ala Tyr
 85 90 95

Val Glu Glu Asp His Val Ala His Ala Leu Ala Gln Thr Val Pro Tyr
 100 105 110

Gly Ile Pro Leu Ile Lys Ala Asp Lys Val Gln Ala Gln Gly Phe Lys
 115 120 125

Gly Ala Asn Val Lys Val Ala Val Leu Asp Thr Gly Ile Gln Ala Ser
 130 135 140

His Pro Asp Leu Asn Val Val Gly Gly Ala Ser Phe Val Ala Gly Glu
 145 150 155 160

Ala Tyr Asn Thr Asp Gly Asn Gly His Gly Thr His Val Ala Gly Thr
 165 170 175

-continued

Val Ala Ala Leu Asp Asn Thr Thr Gly Val Leu Gly Val Ala Pro Ser
 180 185 190

Val Ser Leu Tyr Ala Val Lys Val Leu Asn Ser Ser Gly Ser Gly Thr
 195 200 205

Tyr Ser Gly Ile Val Ser Gly Ile Glu Trp Ala Thr Thr Asn Gly Met
 210 215 220

Asp Val Ile Asn Met Ser Leu Gly Gly Pro Ser Gly Ser Thr Ala Met
 225 230 235 240

Lys Gln Ala Val Asp Asn Ala Tyr Ala Arg Gly Val Val Val Val Ala
 245 250 255

Ala Ala Gly Asn Ser Gly Ser Ser Gly Asn Thr Asn Thr Ile Gly Tyr
 260 265 270

Pro Ala Lys Tyr Asp Ser Val Ile Ala Val Gly Ala Val Asp Ser Asn
 275 280 285

Ser Asn Arg Ala Ser Phe Ser Ser Val Gly Ala Glu Leu Glu Val Met
 290 295 300

Ala Pro Gly Ala Gly Val Tyr Ser Thr Tyr Pro Thr Ser Thr Tyr Ala
 305 310 315 320

Thr Leu Asn Gly Thr Ser Met Ala Ser Pro His Val Ala Gly Ala Ala
 325 330 335

Ala Leu Ile Leu Ser Lys His Pro Asn Leu Ser Ala Ser Gln Val Arg
 340 345 350

Asn Arg Leu Ser Ser Thr Ala Thr Tyr Leu Gly Ser Ser Phe Tyr Tyr
 355 360 365

Gly Lys Gly Leu Ile Asn Val Glu Ala Ala Ala Gln
 370 375 380

<210> SEQ ID NO 13
 <211> LENGTH: 20
 <212> TYPE: DNA
 <213> ORGANISM: Artificial Sequence
 <220> FEATURE:
 <223> OTHER INFORMATION: phi-105 ORF 19 promoter-specific primer

<400> SEQUENCE: 13

atagacaatc ggcggttaac 20

<210> SEQ ID NO 14
 <211> LENGTH: 478
 <212> TYPE: DNA
 <213> ORGANISM: phi-105 bacteriophage
 <220> FEATURE:
 <223> OTHER INFORMATION: phi-105 ORF 19 promoter

<400> SEQUENCE: 14

tttattggaa ttaagagtct ctgggactgc tcttgtaa at gtccttgta atttaaagga 60
 tattgacata acgaaatggt tgtgtaaaac agggagatta tatcttgata aggtaagaa 120
 atttgaaata gttactatct tttcccatga cgtagaaaat caaaagatta taacagaatg 180
 ggagtcactc cgcagagagg ctttaccgga acaatttgat tcataagaac taattagtag 240
 cgctttccaa tggaggcgct tttttatttg gtagttgca taccactaaa gatgttcagg 300
 tgcacatgag cattggagga aaggaacgct ttagggggaa gggaaacctt taacagctct 360
 taatcccctc tgattttatg ttctctgtaa actgcgtccg gtaaatctca ggatagacaa 420

-continued

 tcggcgggta acggccttgag tcgsggggca gtttagaaaag aatatgattg gagggatt 478

<210> SEQ ID NO 15
 <211> LENGTH: 30
 <212> TYPE: PRT
 <213> ORGANISM: Bacillus subtilis
 <220> FEATURE:
 <223> OTHER INFORMATION: signal peptide from Bacillus subtilis

<400> SEQUENCE: 15

Met	Arg	Ser	Lys	Lys	Leu	Trp	Ile	Ser	Leu	Leu	Phe	Ala	Leu	Thr	Leu
1				5					10					15	
Ile	Phe	Thr	Met	Ala	Phe	Ser	Asn	Met	Ser	Ala	Gln	Ala	Ala		
			20					25					30		

What is claimed is:

1. A process for production of Bacillus protease that comprises a recombinant Bacillus strain transformed with an expression vector comprising

- a. A promoter region of the ORF19 of the bacteriophage phi-105 (SEQ. ID No 14), and
- b. A gene from Bacillus strains encoding said protease (SEQ. ID Nos. 7 or 9).

2. The process according to claim 1, wherein said vector comprising a promoter which is a functional derivative of the promoter region of the ORF19 of the bacteriophage phi-105.

3. The process according to claim 1, wherein said vector comprising a protease gene which is a functional derivative of SEQ. ID Nos 7 or 9.

4. The process according to claim 1, wherein said vector comprising a protease gene from any prokaryotic and eukaryotic living organisms which has over 60% homology with SEQ. ID Nos 7 or 9.

5. The process according to claim 1, wherein said vector comprising a mutated or artificially synthesized protease gene which has over 60% homology with SEQ. ID Nos 7 or 9.

6. The process according to claim 1, in which the promoter is induced by heat.

7. The process according to claim 1, wherein said protease genes are in frame with any heterologous signal peptides.

8. A process according to claim 1, further comprising the steps of separating or purifying the said protease.

9. A method for producing a polypeptide, comprising:

- (a) cultivating a Bacillus cell in a medium conducive for the production of a polypeptide, wherein the Bacillus cell comprises a nucleic acid construct comprising a Φ 105MU331 promoter in which the Φ 105MU331 promoter sequence is operably linked to a nucleic acid sequence encoding the polypeptide; and
- (b) isolating the polypeptide from the cultivation medium.

10. The method of claim 9, wherein the nucleic acid sequence encodes a protease subtilisin gene product, Carlsberg, cloned from a *Bacillus licheniformis* strain (ATCC No. 10716), the protease subtilisin BPN^l gene product from

Bacillus amyloliquifaciens (ATCC No. 23844), or a functional derivative thereof, or a combination thereof.

11. The method of claim 9, wherein the nucleic acid sequence encodes a protease subtilisin gene product coding sequence, Carlsberg, cloned from a *Bacillus licheniformis* strain (ATCC No. 10716)(SEQ ID NO: 7), the protease subtilisin BPN^l gene from *Bacillus amyloliquifaciens* (SEQ ID NO: 9)(ATCC No. 23844), or a combination thereof.

12. The method of claim 9, wherein the nucleic acid sequence encodes a protease subtilisin gene product coding sequence, Carlsberg, cloned from a *Bacillus licheniformis* strain (ATCC No. 10716)(SEQ ID NO: 7), or the protease subtilisin BPN^l gene from *Bacillus amyloliquifaciens* (SEQ ID NO 9)(ATCC No. 23844) operably linked to the 30 amino acid signal peptide of *B. subtilis* 168 subtilisin E.

13. The method of claim 9, wherein the nucleic acid construct further comprises a selectable marker gene.

14. The method of claim 9, wherein the selectable marker is the CAT gene.

15. The method of claim 9, wherein the Bacillus cell contains no selectable marker gene.

16. The method of claim 9, wherein the nucleic acid sequence encodes a polypeptide heterologous to the Bacillus cell.

17. The method of claim 9, wherein the polypeptide is a hormone or variant thereof, enzyme, receptor or portion thereof, antibody or portion thereof, or reporter.

18. The method of claim 17, wherein the enzyme is an aminopeptidase, amylase, carbohydrase, carboxypeptidase, catalase, cellulase, chitinase, cutinase, cyclodextrin glycosyltransferase, deoxyribonuclease, esterase, alpha-galactosidase, beta-galactosidase, glucoamylase, alpha-glucosidase, beta-glucosidase, invertase, laccase, lipase, mannosidase, mutanase, oxidase, pectinolytic enzyme, peroxidase, phytase, polyphenoloxidase, proteolytic enzyme, ribonuclease, transglutaminase, or xylanase.

19. The method of claim 9, wherein the Bacillus host cell is a *Bacillus alkalophilus*, *Bacillus amyloliquefaciens*, *Bacillus brevis*, *Bacillus circulans*, *Bacillus clausii*, *Bacillus coagulans*, *Bacillus firmus*, *Bacillus lautus*, *Bacillus lentus*, *Bacillus licheniformis*, *Bacillus megaterium*, *Bacillus pumi-*

lus, *Bacillus stearothermophilus*, *Bacillus subtilis*, *Bacillus thuringiensis*, *Bacillus thermoleovorans* strain (ATCC No. 43506), *Bacillus subtilis* strain 168, or *Bacillus subtilis* strain MU331.

20. The method of claim 9, wherein the nucleic acid sequence encodes a polypeptide homologous to the *Bacillus* cell.

21. The method of claim 20, wherein the polypeptide is a protease.

22. The method of claim 21, wherein the *Bacillus* cell is a *Bacillus amyloliquefaciens* cell.

23. The method of claim 22, wherein the *Bacillus* cell is a *Bacillus licheniformis* cell.

* * * * *