

The City in a Building: a Brief Social History of Urban Hong Kong

Eunice Seng

The University of Hong Kong
eseng@hku.hk

Keywords: urban density; composite building; industrialization; spatial contestations; urban domesticity; public and private

Introduction

Post-World War II Hong Kong was politically and economically valuable to the newly formed People's Republic of China, especially with the outbreak of the Korean War in 1950 and the intensification of the Cold War in East Asia. The imposition of a trade embargo against the People's Republic of China (PRC) by the United States in December 1950 was followed by a partial embargo on the export of strategic materials by the United Nations in May 1951, and by a tightening of British export control in June. Caught between the Chinese communists and the Republic of China (ROC) Kuomintang in Taiwan, Hong Kong was also faced with the challenge to transform its economy and it did so by embarking on a full-fledged industrialization process. During the enactment of the embargo in the 1950s, Hong Kong provided strategic materials such as medical supplies, petrol and automobile and building supplies for the PRC, as well as food supplies during the famine caused by the Maoist policy known as the Great Leap Forward. When the embargoes were lifted, Hong Kong resumed its position as the PRC's main entrepôt in the 1970s, and became the channel through which the latter obtained modern technology, skills, and capital.¹

The postwar decades up to the 1970s were a period of experimentation and reorganization in planning and housing development.² In 1946, soon after the end of the war, the planner Patrick Abercrombie was invited to carry out the first comprehensive urban planning for Hong Kong, for which he produced a report in 1949 that highlighted the need for infrastructural connection between Hong Kong Island and Kowloon. The 1950s saw a number of new town development trials. In 1954, the Resettlement Department was formed out of the Urban Council (UrbCo), following the completion of the Shek Kip Mei Estate and the enactment of the Housing Ordinance, a year after a fire in Shek Kip Mei that rendered over 50,000 people homeless.³ The Resettlement Department published an annual report from 1954. In 1973, the Government under the British Governor Murray MacLehose, established the Hong Kong Housing Authority (HKHA) under a revised housing ordinance and announced a ten-year public housing plan. The Resettlement Department and the Building Section of the Urban Services Department were merged to form the Housing Department, which acts as the executive body. HKHA published its first annual report that year, chronicling its work dating from 1 April 1973.

1 Steve Tsang, *A Modern History of Hong Kong* (Hong Kong: Hong Kong University Press, 2004), 56-60.

2 The first Town Planning Board was set up in 1922, but the Town Planning Ordinance was enacted only in 1939, right before the outbreak of the war. Previously, building and planning schemes were based on the 1841 colony lease conditions and later the Building Ordinance of 1889 that regulated density control, height limit, yard, lane and open space. The Buildings Ordinance Office (BOO) was first set up under the former Public Works Department (PWD), which began publishing an annual report from 1897. The PWD was succeeded by the Building Development Department in 1982, which comprised the two constituent parts - the Building Ordinance Office and the Architectural Office.

3 Founded as the Sanitary Board in 1883, the Urban Council (UrbCo) was responsible for municipal services on Hong Kong Island and in Kowloon. The municipal services were provided by the council's Urban Services Department. The Board was renamed the Urban Council when new legislation was passed in 1936 expanding its mandate.

From the onset, within Hong Kong's building regulations, the definition of a "composite building" refers to a building that contains domestic and other functions.⁴ From the enactment of the 1956 Building Ordinance based on volumetric control to the 1962 amendment on plot ratio control through the 1970s, over 1,500 composite buildings above fifteen stories were built in Hong Kong. They are located in the densest parts of the city, such as in North Point, along major thoroughfares in Tsim Sha Tsui, Tai Kok Tsui and To Kwa Wan and on reclaimed land in Kowloon. Of these, at least twenty contain populations the size of a town; each occupies an entire urban block. The largest and most populous of these contains almost 10,000 inhabitants excluding unregistered tenants and illegal squatters. Emerging amidst the economic, social and political exigencies of post-war Hong Kong, the high-rise composite building exemplifies the paradox of collective sociability within an individual privatized space. Not only does the high-rise composite buildings produced under the conditions of heightened density and speculative land and building development find no equal in any other city, but they also constitute a substantial amount of private housing stock, with many containing spaces of continual confrontation between public urban life and domestic life.

How did the mixed-use composite building become the dominant architectural type in the immediate decades following 1949? Its ubiquity owed much to three factors: (1) it provided spatially compact housing for a city with an escalating population; (2) it offered expanding middle class opportunities for investing in relatively inexpensive and profitable properties boosted by the introduction of multiple ownership and the mortgage system; and (3) it was an agent of the expansion of the construction industry, which bolstered by the relocation of building expertise from the Mainland. Demography, economy and technology, however, do not sufficiently account for how Hong Kongers and later, foreigners, domestic workers, asylum seekers and fugitives, made their homes in the composite building. It embodies the containment of a social heterogeneity in a unifying framework defined by the collision of the private and the public, the imbrication of the urban and domestic, and the continuity of every aspect of urban space in the interior. To understand the Hong Kongers' acceptance of and adaptation to the composite building, it is necessary to excavate the cultural expectations of domestic and urban space embedded in the discourses of Hong Kong architecture and everyday life.

While cities in Asia were encountering social and economic exigencies in their decolonizing struggles and nationalizing processes, colonial Hong Kong, between 1947 and 1955, underwent a meteoric rise of industrialization attributed to two political events around the Colony. The first was the revolutionary take-over of China in 1949, which saw droves of migrants and refugees fleeing across the border from Mainland China, bringing along the resources of new labor, capital and technical skills and experience for industrial development. The second was the Korean War and the United Nations Embargo on trade in strategic articles with China in 1951, which constituted a great blow to the trading role of the city and forced it to turn to the development of other industries to compensate for the losses in trade.⁵ With seemingly unlimited supply of cheap labor, adequate capital from local and foreign sources and experiences and capricious entrepreneurship, low tariffs and a laissez-faire capitalism, the per capita income tripled between the first post-war decade and 1969. By 1971, the urban density was 750 people to the acre.⁶ Over a third of the labor force was engaged in industrial employment and the city saw an expansion in the number of labor unions and the size of their membership.⁷ Only one fifth of Hong Kong's primarily immigrant families were born locally.⁸

To a large extent, the composite building was the architectural corollary of the laissez-faire system, which produced the city's highly speculative built environment. Initially constructed to

4 Within Hong Kong's building regulations, "composite" refers to multiple functional uses – always inclusive of the domestic – within a single building complex.

5 Fai-Ming Wong, "Industrialization and Family Structure in Hong Kong", *Journal of Marriage and Family* 37, 4 (Nov. 1975), 988.

6 Charles Smith, "HK's growth generates expectations", *South China Morning Post* (Jul. 5, 1971), 32.

7 Wong, "Industrialization", 989.

8 *Ibid.*: 993.

accommodate the burgeoning industrialized middle-class population, by the mid-1970s, many composite buildings were used for a variety of commercial and industrial purposes including small cottage industries such as spice and textile production, packaging and finishing, retail and storage. The industrial process extended from flatted factories into the domestic sphere where women assembled and packaged plastic products, toys and finishing work for textiles, to supplement the household income. Triggered by the shift from a manufacturing base to service industries in the late 1980s, many of these industries have since relocated to farther industrial areas or are significantly reduced in scale — such collectives have gradually been replaced by multifarious groups whose livelihoods do not rely on industrial-based work.

In their study on the small industrial unit in Hong Kong, Dennis John Dwyer and Chuen-Yan Lai examined the second phase of industrial expansion in Hong Kong through internal changes in capital use as a consequence of the embargo placed upon trade with China during the Korean war, where textile, specifically clothing, and later plastics were the leading industries. The expansion of the urban industrial population was accompanied by the proliferation of small enterprises; many factories were found in single rooms in residential buildings and in shacks on the hillsides in refugee areas. They identified that as such, the physical accommodation of these industries is integrated into the economic and urban planning of the city, where the policy of large-scale squatter resettlement implicated the relocation of the small industrial units. Concurrent to the building of factory blocks (with heights ranging from five to seven stories) undertaken by the colonial Resettlement Department was the construction of the composite building types by private enterprise — these include also higher and denser version of the *tonglau* (shop-houses) — where the flat units were immediately susceptible to conversion into small factories. In addition, in Tai Kok Tsui, for example, there were existing buildings that were taken over by specific industry, such as garment making and plastics, as well as buildings where the lower floors were occupied by industrial units with the upper floors residential.⁹ The geographer Victor Sit deepened the study on the accommodation of small industries by examining the different types of factories, including private domestic units that were converted to industrial uses. These accounted for 5.65 per cent of the total private dwelling units in 1971, most of which were housed in the post-war composite buildings — “modern apartment blocks,” according to Sit.¹⁰ In a 1998 article, he suggested that the SAR government should extend its industrial economy to the larger Pearl River Delta, a scenario which has since been realized and witnessed the departure of factories in domestic spaces (FID), and other types of industry, such as guest houses and offices, tend to take their place.¹¹

As private co-operative buildings, many contain an agglomeration of flats, shops, offices, factories, dormitories, hostels, nurseries, clinics, restaurants, clan associations, temples and hosts of other religious, medical, educational and recreational functions. The architecture manifests the way its developers, architects and builders projected the notions of a consumerist society: each square foot of habitation is rationalized and quantified. Yet the varieties of programs, spatial adaptations and contestations within testify to the combination of pragmatist logic and human whim that drives and defines the city. How did these tensions and everyday acts of resistance shape the spaces of the composite buildings and the city?

“A Problem of People” as the Thesis of Density

When the British retook Hong Kong in 1945, the population of the colony had been depleted to around 600,000. By 1956, it had increased more than fourfold to over 2.5 million. Amongst these, about one million new arrivals were from Mainland China, of which 700,000 were

9 D.J. Dwyer and Lai Chuen-Yan, *The Small Industrial Unit in Hong Kong: Patterns and Policies* (Yorkshire: University of Hull Publication, 1967).

10 Victor Sit, *Made in Hong Kong* (Hong Kong: Summerson Eastern Publishers Ltd.), 81-88.

11 Victor Sit, “Hong Kong’s ‘Transfer’ Industrialization and Industrial Geography”, *Asian Survey*, 38, 9 (Sep. 1998), 903-904.

identified as refugees.¹² The rapid population increase put immense pressure on the provision of housing and public facilities. The first chapter of the Hong Kong Annual Report in 1956 titled “A Problem of People”, highlighted the government’s sense of urgency. It identified the problem of a vast immigrant population as a paramount challenge that had an influence on all areas of public policies. Amongst the policies, the large-scale resettlement program and public housing program represented major steps undertaken to cope with the changes brought by the post-war influx of Mainland immigrants. It pointed out that because of the scarcity of land in Hong Kong, the actual population was twice the normal capacity of Hong Kong, which was 1.2 million.¹³ This was the moment when the thesis that Hong Kong, with its shortage of land, was threatened by immigration from Mainland China, became one of the prominent features of public discourse.

On October 10, 1956, the National Day of the Republic of China, violent riots broke out, which started with looting and attacks by pro-Nationalist civilians on pro-Communist civilians and their property in Hong Kong. Known as the *Double Ten* riots, they were the culmination of tensions accumulated since 1949 by the majority of the population who were outraged at the possibility of Hong Kong being handed back to China if the entrepôt trade could not be maintained. The famine in China, triggered by Mao’s Great Leap Forward (begun in 1958) and the 1962 Great Proletarian Cultural Revolution, brought an additional 100,000 immigrants who crossed the border into Hong Kong. The colonial institutions inherited from the pre-war era, when Hong Kong was largely a temporary stopover for transient businessmen and workers, were severely challenged by the disenfranchised majority of residents who were little more than colonial subjects allowed the “privilege” of living in a “foreign” territory. This political set-up was increasingly untenable as the immigrants settled down. The May 1967 street riots were the tipping point that saw the government shaken from its complacency. In the following decades, it began introducing extensive public reforms to avoid political alienation. Housing was at the frontline.

Resettlement was already a “serious” priority upon the British return from 1947.¹⁴ Of particular interest in the Annual Departmental Reports of the Commissioner for Resettlement were the sections that dealt with the economics of multi-story resettlement and the method of calculating the rent per unit. The Public Works Department built the early resettlement estates such as Shek Kip Mei, So Uk and Li Cheng Uk, and the first low-cost housing estate at North Point was built by the former housing authority (founded in 1954). The Government Low-cost Housing Program was formally implemented in 1961, to provide higher quality rental accommodation. From 1965, high-rise resettlement blocks with improved facilities, such as a private lavatory and balcony in each flat, were built. At this time, the population in public housing estates reached one million, which accounted for almost a third of the entire population. The deterioration of the political, social, and economic conditions in China and the Western trade embargo due to the Korean War ended Hong Kong’s role as its premier *entrepôt*; and spearheaded industrial development of the 1950s. The economic transformation during that decade was spurred by the provision of development conditions for industries — from the improvement of local infrastructure and water supplies, making land available for large factories to be built particularly in new towns and constructing low-cost multi-story industrial buildings in resettlement estates for light industries. The development of the first industrial town in Kwun Tong coincided with the establishment of the Housing Authority in 1954.

Concurrently, in the early 1950s, the problem of housing for the middle class was highlighted in the trade journal *The Hong Kong and Far East Builder*. The questions of who, what and where to

12 Hon-Chu Leung, “Immigration and citizenship”, in *Remaking Citizenship in Hong Kong: Community, nation and the global city*, edited by Agnes S. Ku and Ngai Pun (London; New York: Routledge, 2004), 101.

13 Patrick Abercrombie, *Hong Kong: Preliminary Planning Report* (Hong Kong: Government Printer, 1949). See R. Bristow, *Land-use Planning in Hong Kong: History, Policies and Procedures* (Hong Kong, Oxford University Press, 1987), 2-5 and 108. This notion of capacity and understanding of density took into account Patrick Abercrombie’s 1948 plan for Hong Kong that recommended an even development of new Towns and the city center. The Report recognized, however, that Abercrombie’s scheme was no longer valid because it was based on a significantly lower projection of population growth.

14 “Government Resettlement Work”, *The Hong Kong & Far East Builder* 12, 5 (1956), 71-72.

COMPACT FLATS IN BIG DEMAND BY MIDDLE CLASSES

Architects: — E. Y. Wu, C. N. Chow
and Associates.



THE urgent need for compact accommodation for Hong Kong's middle classes, both Chinese and European, is continually being spotlighted. An excellent example of the type of residence being sought is that provided in the recently completed Broadview Mansion in Wong Nei Chong Road, Happy Valley.

This 11 storey building was designed to fully utilise the floor area. Only 400 square feet out of a total of 4100 square feet of building area on each floor are taken up by staircases, lifts, entrance hall and corridors. This area represents less than 10 per cent of the building area. The almost complete absence of corridors is one of the main features of the building. About the only wasted space in each flat is a small three feet by three feet "hall" between two bedrooms.

The new building contains four European style apartments to each floor — the front pairs face the Racecourse and have an area of about 1150 square feet, while the rear two, smaller apartments, facing Ventris Road, have an area of about 700 square feet.

Each apartment contains a living/dining room, three bedrooms, two bathrooms (only one for the rear apartments), kitchen, servants' room with a servants' W.C.

The servants' quarters are particularly well situated in all flats, being placed out of the way at the rear of the kitchen and adjacent to two verandahs, another feature of every flat.

Fig. 01: "Compact Flats in Big Demand by Middle Class," article in *The Far East Builder* (1964).

build were the focus of a 1955 issue centered on the need for building societies to erect middle class co-operative housing. (Fig.01) The *Lady Grantham Villas* in Taikoktsui Kowloon, built by the non-profit Hong Kong Economic Society, opened in July 1955.¹⁵ The seven five-story blocks of flats following a "strictly practical, utilitarian and serviceable" design were the first examples of subsidized low-cost housing sold to the public. On the one hand, this issue of the journal revealed the inadequacy of one-off housing projects for accommodating the lower class (this was evidenced by the *Shek Kip Mei* Resettlement Estate) and, on the other hand, it anticipated the implementation of the low-cost housing program starting with North Point Estate in 1957. At the same time, it was the beginning of private interests in affordable housing that saw the spate of composite buildings after 1956. The editors identified the difficulty of obtaining financial assistance on a reasonable interest basis, the limited level ground and impossibility of suburban growth, as well as the need for improvement of roads and transport facilities. They recommended three ways in which the government could promote cooperative building of middle-class housing: by town planning suitable areas and improving road access to them; by selling land by private treaty to *bona fide* and approved cooperative societies at a reasonable value; and by extending financial assistance for this class of building.¹⁶

15 "Lady Grantham Villas", *The Hong Kong & Far East Builder* 11, 4 (1955), 57-58.

16 "Editorial: And Now, Middle Class Co-operative Housing?", *The Hong Kong & Far East Builder* 11, 5 (1955), 5. Cf. "What To Build", *The Hong Kong & Far East Builder* 15, 6 (1961), 42.

Multiple Ownerships and the Mortgage System

A decisive shift occurred in the meantime, as the Chinese developer Ng Tor Tai introduced the notion of multiple ownership to Hong Kong's real estate market.¹⁷ Prior to 1953, real estate transactions involved entire buildings. Whereas land sales by public auction continued, developers could now resell parcels and units to other small-time developers and individual buyers. Immediately following this, in 1954, a developer named Henry Fok Ying Tung introduced the mortgage system.¹⁸ In 1956, Fok's National Investment Company Limited built the Empire Court in Causeway Bay, a seventeen-story apartment block designed by C.T. Wong. It was the tallest building in Hong Kong at the time of its completion. The first three floors were given to shops and offices, the upper floors contained apartments ranging from studios to three-bedroom apartments and the seventeenth floor was a penthouse for Fok himself.¹⁹ By then, there were more than 500 newly-registered developers who had secured financial support from banks, and government policy was favorable to the demolition of old buildings. 1800 buildings were completed in 1960 alone totaling an investment of HK\$11.5 billion, which was almost twice of that in 1958.²⁰ While most of these were built by private developers, some building societies were involved too. Earlier, in a 1955 issue of the trade journal *The Hong Kong & Far East Builder* featuring the housing projects built by The Hong Kong Chinese Civil Servants' Association, the Hong Kong Housing Society, and building co-operatives (such as the Belcher's), as well as the government's resettlement schemes, the editorial states explicitly the return on capital investment as an incentive for the building of middle-class co-operative housing by building societies.

Volumetric, Vertical and Setback

In 1955, the Building (Planning) Regulations in Hong Kong were revised and the height limit of buildings was increased to one and a half times the width of the adjacent road.²¹ The setback act was introduced to prevent buildings from obstructing natural light in footpaths and the streets. The impact on private apartment blocks was visible. In the main thoroughfares of Kowloon — where the transaction of land blocks was high and much building activity was to take place — in the following few decades, apartment complexes the size of an urban block with the top few floors set-back began to appear. The developers hired reputable foreign émigrés and local architects, including Eric Cumine, Szeto Wai, Lamb Ping Yin, John Sousa Moraes, and Su Gin-Djih, to design these composite buildings. Some builder-developers like Tai Cheong Construction Company hired realtor companies that provided architectural design services. Harriman Realty Company Limited was the architectural office responsible for the design of the sixteen-story Mirador Mansion on Nathan Road in Tsim Sha Tsui Kowloon, in 1959. Comprising three lower floors of shops, it occupied an entire block. Its eighteen-story neighbor Chungking Mansions designed by American-trained Lamb of P.Y. Lamb, Hazeland & Co., was completed in 1961. Moraes had designed Ocean View Court in 1957 for Kiu Fung Investment Co. Ltd., a consortium of a developer firm, a construction firm and managers of the whole project. All these composite buildings contain elevators.

A new regulatory measure based on plot ratio and site coverage was introduced in 1962 and enacted in 1966 for controlling building density.²² Prior to this date, many developers tried to

17 Bangyan Feng, *One Hundred Years of Real Estate in Hong Kong* [Xianggang di chan ye bai nian 香港地产业百年] (Shanghai: Oriental Publishing Center, 2007), 66.

18 *Ibid.*, 85-87.

19 "Empire Court", *The Hong Kong & Far East Builder* 12, 3 (1956), 19-20.

20 Feng, *One Hundred Years*, 73.

21 In Britain, the Clean Air Act was introduced to reduce air pollution in 1956 after years of debates. This was followed by the amendment of the Rights of Light Act in 1959 for the purpose of preventing the access and use of light to be enjoyed from being taken without interruption.

22 Density zoning was adopted in 1966. "Density Zoning Adopted", *Far East Architect & Builder* (May 1966), 27-28. Zones 1, 2 and 3 referred to urban, suburban and rural respectively. The building demolition regulation was enacted in 1964.

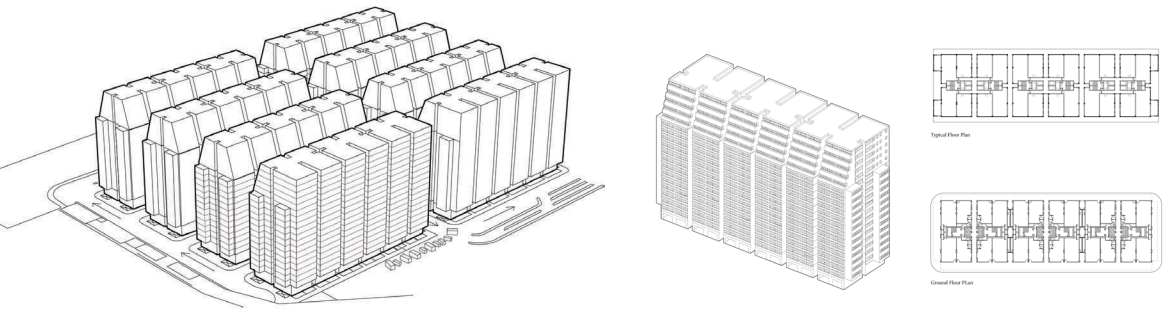

Fig. 02: Manking Building, one of eight eighteen-story blocks in Man Wah Sun Chuen, designed by Eric Cumine in Jordan, Kowloon, 1967.

obtain planning permission. In the ten-year period between the two ordinance amendments, thousands of composite buildings were approved, and many were built in the late 1960s and 1970s. One of the most spectacular of these is Man Wah Sun Chuen, a development of eight eighteen-story apartment blocks in Jordan, Kowloon (1964-1967). (Fig. 02) Each block contains about 419 units and houses more than 1,300 people. This is comparable to the Unité d'Habitation block in Marseilles (1947-52) which contains 337 apartments, a hotel and shops. The then newly established Ka Lin Real Estate hired AA-trained Cumine who had taught at St. John's University in Shanghai, together with other proponents of Bauhaus ideology, and ran the most prolific architectural office in post-war Hong Kong.²³ Cumine's massive block with its tapered profile reveals the economic imperative behind the literal and formal translation of the 1956 Development Control regulation of buildings by volume. The estate towers fortress-like over the streets that front it, forming an urban wall that stood defiantly against a shoreline continually reconfigured by reclaiming.

Reinforced Concrete Construction and the Predominance of the Brutalist Aesthetic

The 1953 Korean War had a significant impact on the development of the construction industry in Hong Kong with investment from many Shanghainese entrepreneurs and builders who chose to remain in Hong Kong. Having fled the Mainland during the political upheavals of the 1940s, they brought in building technology like fine plastering and piling machinery, and advanced the use of reinforced concrete, which was introduced to the colony in 1947.²⁴ The Shek Kip Mei resettlement estate, constructed by the Fok Lei Company in a year since the 1953 big fire that rendered 58,000 people homeless, was the first housing project to use concrete structural walls.²⁵ By the mid-1950s, reinforced concrete had become the most common building material for housing construction in Hong Kong.²⁶ From 1960, when it was obvious that they would no longer return to the Mainland, Shanghainese contractors ramped up their investments in Hong Kong and introduced larger and more advanced machinery like cranes and large concrete piling. As the construction industry was the main sponsor of *The Hong Kong and Far East Builder*, the buildings that were reported in the journal were main protagonists in the advertisements of the industry products.²⁷ There was nothing hidden as to the forces at play behind building form and aesthetics.

In Britain, in December 1955, architectural theorist Reyner Banham had just published an article titled "The New Brutalism" in the *Architectural Review*. He identified the term to have begun as

23 Cumine designed North Point Estate (1958) and was master planner for So Uk Estate (1961) in Cheung Sha Wan, Kowloon.

24 The Engineering Society of Hong Kong was established that year.

25 "Resettlements", *The Hong Kong & Far East Builders* 5, 11 (1955), 62-64.

26 Luke S.K. Wong (ed.), *Housing in Hong Kong* (Hong Kong: Heinemann Educational Books, 1978), 95-100. See also, "Tower Court", *The Hong Kong & Far East Builders* 6, 10 (1953), 9. In 1955, the use of reinforced concrete was regulated and architects needed to co-sign the drawings with a registered structural engineer. The PWD established a laboratory in North Point to conduct tests on the control of building materials across Hong Kong. In 1957, local factories began to manufacture high strength steel re-bar. Escalators were introduced to shopping malls and podium retail began to emerge.

27 For example, Mirador Mansion's two escalators and eight elevators were supplied by Otis, and used Vibro Piling for the foundations. "Mirador Mansion", *The Hong Kong & Far East Builder* 13, 6 (1957-1958), 19-20.

a polemic of anti-Communist abuse and was formalized by architects like Louis Kahn, Alison and Peter Smithson as a “ruthless adherence to one of the basic moral imperatives of the Modern Movement — honesty in structure and material”.²⁸ He defined the “New Brutalist building” as endowed with “memorability as an image,” “clear exhibition of structure,” and “valuation of materials ‘as found’”.²⁹ In terms of the scale and intensity of building, Hong Kong easily rivaled Britain in the 1950s. In particular, the construction of new brutalist buildings — all those that satisfied Banham’s three criteria — far surpassed the few examples that he discussed in his essay. Following Banham’s argument, the defining difference was that the composite buildings in Hong Kong were sites of political and economic contingency, while in Britain this architecture was ideologically driven. The Hong Kongese designers did not intend these buildings to embody communist or anti-communist ideas (anti-symbolic or anti-heroic), yet the intersection of political, economic and social factors produced these large concrete blocks that contained spaces of domesticity and livelihoods, deeply entangled with the urban imperatives of the city.

From homes for the urban class to sites of resistance

Two episodes centered around four, or rather, two pairs of composite buildings as protagonists of urban contingency in 1966 and 1967. The narratives and contexts surrounding the development of these buildings from their original purpose, as homes for the urban middle-class, to the deterioration of their status in the city, as enclaves of political and economic disenfranchised *others* (refugees, prostitutes, illegal businesses, radical leftists. . .), revealed a society undergoing tremendous transition in the 1960s. These spaces, akin to Michel Foucault’s heterotopias, which thrive on non-hegemonic conditions, were already actual sites where the middle-class Chinese family confronted multifarious others every day. Within a few years of their opening, the intense interiorization — subdivision and interior built-up of rooms and spaces — of these blocks, sprung from the need to accommodate numbers of people far exceeding the original capacities, catapulted these buildings to the forefront of the escalating tensions between the city’s predominantly Chinese migrant population and the British colonial government; these conflicts were publicized in the local press media.

Protest Street and Hideout Homes

The twenty-seven story Kiu Kwan Mansions completed in 1966 was the tallest building in Hong Kong at the time of its completion. It contained 624 units each between 400 and 600 square feet in size. In 1967, the building was home and refuge for many of the leftists involved in the 1967 riots. Between May and December 1967, fifty-one people were killed, more than eight hundred injured, and over eight thousand “bombs” were detonated (of which 1,100 were real) in the clash between the pro-Communists and the colonial establishment.³⁰ North Point was then predominantly populated by Fujianese, many of whom supported the leftists, and resided in Kiu Kwan Mansions. The building was designed by Hong Kong architect Steven Yue directly across the twenty-three storied New Metropole Building (later known simply as Metropole Building), designed by Hong Kong architect Tam Heung Sing. (Fig. 03)

The former housed many employees of Mainland-owned companies and leftist union offices. According to police constable James Elms, who lived in North Point and worked at the Bay View Police Station nearby, on the ground floor of Kiu Kwan Mansion was Wah Fung Chinese Products Emporium, known as the base of operations “for everything as far as the left went.”³¹ He was at home asleep at 1pm on 6 May when tensions escalated at the Hong Kong Artificial

28 Reyner Banham, “The New Brutalism”, *The Architectural Review* (Dec. 1955), 357. He published a book of the same title in 1966: Reyner Banham, *The New Brutalism: Ethic or Aesthetic?* (London: The Architectural Press, 1966).

29 *Ibid.*, 361.

30 Kate Whitehead, “Witnesses to anarchy: the 1967 riots in Hong Kong, by some of those caught up in the violence”, *Post Magazine* (25 Apr. 2017).

31 Whitehead, “Witnesses to anarchy”.

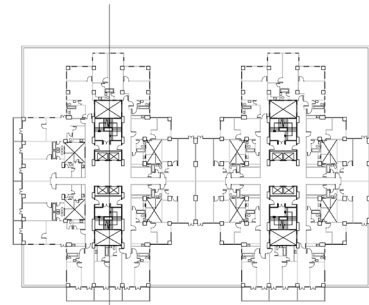
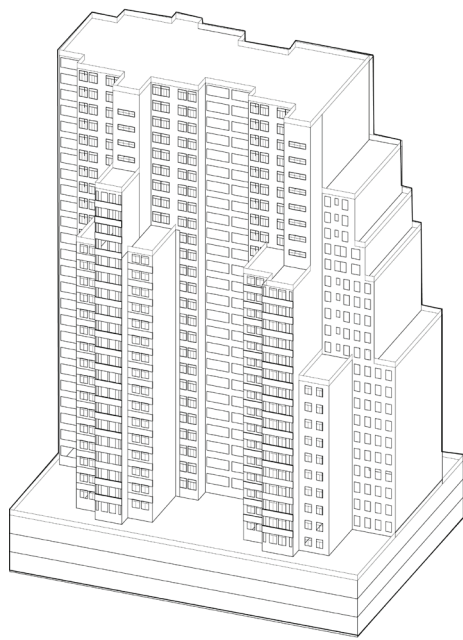

4th floor plan

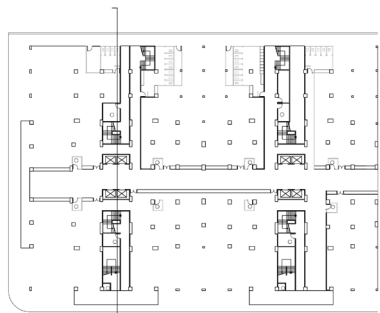

ground floor plan

Fig. 03: Above: Kiu Kwun Mansion designed by Steven Yue in North Point, Hong Kong, 1963.
Below: Metropole Building designed by Tam Heung Sing in North Point Hong Kong, 1972.

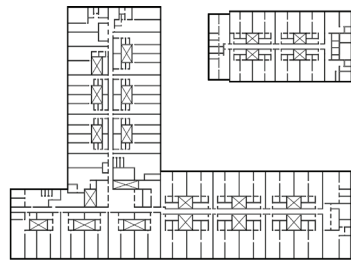
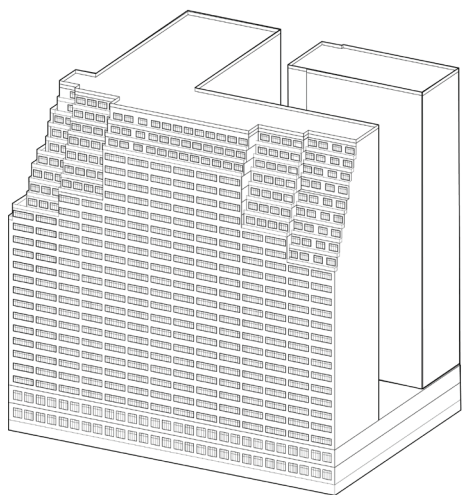

4th floor plan

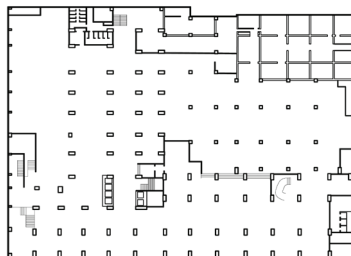

Ground floor plan

Flower Works' San Po Kong factory. Workers disgruntled over wages and the dismissal of twenty-nine machine operators had been locked out, and demonstrations were held as workers from other factories joined in.³² The violence reached its height in July and only subsided in December.

In July 1967, tenants of the two buildings began moving out for fear of being involved with the leftists. Most left their possessions behind. A tenant of Metropole Building interviewed by the *South China Morning Post* revealed that the Communists caused panic when they converted the first and second floors of into what looked like hospital casualty wards.³³ He also said that they went from floor to floor urging the tenants to join them in "heroic struggle against suppression." A few weeks later, the raids of leftist strongholds Kiu Kwan Mansion and Metropole Building began at 6.40am on 4 August. Police cordoned off King's Road and Tong Shui Road nearby. Police landed on the rooftop of Kiu Kwan Mansion by helicopters of the British Aircraft Carrier. The staircase to the roof was also installed with traps such as glass bottles and hidden explosives. A *Fujian* Association on the seventh floor suspected to be a hideout for the patriots was empty.³⁴ Several units on the twenty-sixth and twenty-seventh floors were vacant and unfurnished and contained makeshift tents. Another team of policemen entered the department store through the rear stairs as the entrances to the ground floor arcade were covered with live wires, obstacles, hidden mines of bottled gas bombs and traps. A "watch tower" was found at a hidden corner in the staircase.³⁵

Across the street, police hopped off from the rope stairs hung from the helicopter, as the rooftop of Metropole was not wide enough for landing. They discovered that the first two floors of the Metropole Building, which was still under construction, were converted into a triage center. A well-concealed and efficiently equipped secret hospital was discovered at the rear of the third floor of Metropole Building, with a secret entrance from the back of the house. Windows were painted black and installed with wooden blinds.³⁶ The hospital consisted of a casualty ward, an operating theatre containing an operating table from Shanghai, a radiography clinic, a sterilizing plant for medical instruments, an x-ray machine and a dispensary stocked with pills and bandages made in the Mainland.³⁷ Another small clinic was found on the third floor, which provided supplies to the hospital above. A collection of spears and other weapons were found on the twenty-third floor.³⁸ The building was cordoned, but residents could get in and out of the building with the guidance of the police.

Metropole Building reopened for tenant occupation in 1972. The building comprising a three-story plinth and a L-shaped block and slab block each twenty-stories high contained a total of 1,037 units. For the rest of the decade, it was home to doctors' clinics, export companies, the Hong Kong Conservancy Association, Hong Kong Christian Council, and main distributor offices for Asia Health Equipment Company specializing in "modern health equipment for Southeast Asia", Miller News Operation (distributor for Harper & Row Collier-Macmillan), Arts of Asia Magazine and Aron Enterprises (distributor for sports equipment). A host of other businesses including a travel agency, a publicity company, a manufacturing company specializing in clothing from Pakistan, an escort company and a Japanese restaurant occupied the second and third floors. Metropole International Department Stores Ltd. Supermarket – "the largest and most modern supermarket in Hong Kong" – opened in the basement in January 1975. The ground floor was taken up by a jewelry store and Banque Nationale de Paris, which opened their North Point branch on the ground floor in November that same year. Notwithstanding the owners' attempt to revamp the building from leftist triage to international center, a large

32 "Over 100 Workers held three-hour demonstration", *SCMP* (11 May 1967), 6.

33 "Tenants leaving 'leftist buildings'", *SCMP* (19 July 1967), 9.

34 Fujian is a province in the southeast coast of Mainland China.

35 "Police landed from British helicopter, raided Leftists' base in North Point" ["警察乘英艦直升機從天而降 大舉圍搜北角左派巢穴"] *Kung Sheung Daily News* (5 August 1967), 5.

36 "Well-equipped secret hospital found", *SCMP* (5 Aug. 1967), 6. "Raids on Three Communist Strongholds: Largest Operations since May", *SCMP* (5 Aug. 1967), 6.

37 Gary Ka-Wai Cheung, *Hong Kong's Watershed: The 1967 Riots* (Hong Kong: Hong Kong University Press, 2009), 86.

38 "Raids on Three Communist Strongholds", 6.

Chinese community with Mainland allegiances remained, as evidenced by the many practitioners of Chinese medicine and herbalists, and the concentration of clans and associations from the Guangdong region of South China.

In the months leading up to the police raids, the interior common spaces of the two composite buildings were a continuum of leftist space that extends from King's Road into the shop floors and up to the double-loaded corridors to the roof. Chinese pro-communist propaganda intermingled with daily commercial activities on the street. The column-gridded open plan of the first two floors in the partially occupied Metropole Building corresponded spatially to the open wards of hospitals and was easily converted to a triage center. The labyrinthine Wah Fung Chinese Products Emporium on the ground floor of Kiu Kwan Mansion was a calculated deterrence for trespassers and police.

Work-shops and Factory-homes

A year earlier, across the Victoria Harbour in Tsim Sha Tsui, two composite buildings — Chungking Mansions and Mirador Mansion — were bases of “missile” launches during the intense three-day riots that escalated from peaceful demonstrations against the colonial administration's decision to increase the fare of the Star Ferry crossing by twenty-five percent.³⁹ For a brief moment, between 6 and 8 April 1966, the two buildings, among others along the main commercial thoroughfare Nathan Road, were embroiled in an urban warfare where protestors hurled flowerpots, bottles and rubbish at police officers patrolling the street during a “sweep.”⁴⁰ Hidden inside the densely occupied buildings, the police could only stop the “missiles” by firing shots in the direction in which they were hurled. The sheer size and density of the block made it impossible for the police to locate the perpetrators.

Completed in 1961 and 1959, respectively, Chungking Mansions and Mirador Mansion were microcosms of Tsim Sha Tsui's transformation from a predominantly residential era with trading activities at the harbor to the highly mixed residential-industrial-commercial district after World War II. (Fig. 04). Early advertisements of Chungking Mansions in *Wah Kiu Yat Po* (Overseas Chinese Daily) encapsulated the initial public image of these composite buildings as grand stately homes (“mansions”), targeted at the middle-class Hong Kong and overseas Chinese buyers keen to own a home and a shop within close proximity. In his brief account of Chungking Mansions' history through interviews with its original residents, sociologist Gordon Matthews highlights the disjunction between the “high-class” image of the building and its actual shoddy construction and diverse mix of tenants by the late 1960s, largely due to the onset of the Vietnam War, which saw the transformation of the area into a red-light district, frequented by American naval soldiers transiting the city. These spaces of Chungking Mansions were described by Hong Kong-based novelist Xu Xi in his 2005 novel, *Chinese Walls*, which was set in the 1960s Hong Kong. There were already hostels, restaurants, clothing and leather goods stores, watches and jewelry shops, and a plethora of small businesses. In the eyes of the author-narrator, the protagonist of the short-story is a young prostitute with orange hair who embodies Hong Kong's colonial status — a Chinese territory on loan to the British.⁴¹

Barely a few years after its completion, the domestic status of this building changed from a family-based and private condition to a more public one, with a heterogeneous and transient working-class population. By the late 1970s, many of the original Hong Kong Chinese families had moved elsewhere and were replaced by new Chinese immigrants and South Asians who began to buy the units at lower costs than other locations of the city. The reconfigured “shop-house” in a three-bedroom unit became obvious: it used the front as the workshop, one room for the office as “shopfront”, and the other two rooms in the back for domestic purposes. It became typical for up

39 “Curfew in Kowloon, Specific Order for Rigid Enforcement, Enquiry told”, *SCMP* (9 June 1966): 8.

40 *Ibid.*, 9.

41 Xu Xi, “Chung King Mansion – from Chinese Walls”, *History's Fiction: Stories from the City of Hong Kong* (Hong Kong: Chameleon Press, 2005), 160-183.

Chungking Mansions

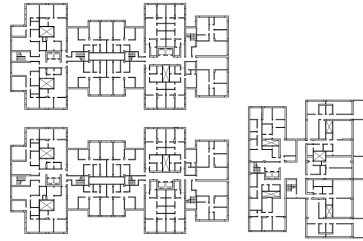
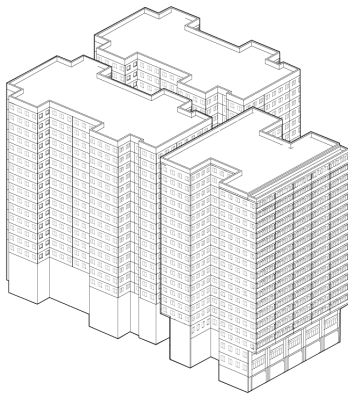

Typical Floor Plan

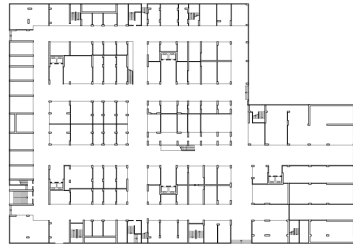

Ground Floor Plan

Fig. 04: Above: Chungking Mansions designed by P.Y. Lamb, Hazelard & Co. on Nathan Road, Tsim Sha Tsui, Kowloon, 1961. Below: Mirador mansion designed by Harriman Realty on Nathan Road, Tsim Sha Tsui, Kowloon, 1959.

Mirador Mansion

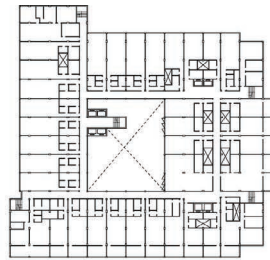
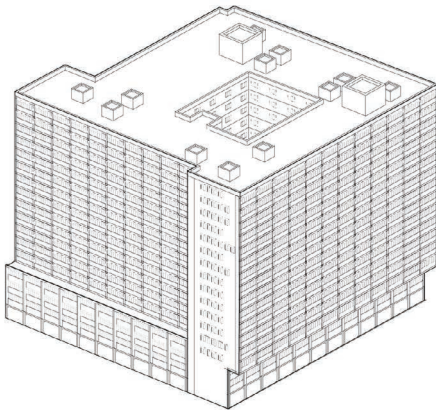

Typical Floor Plan

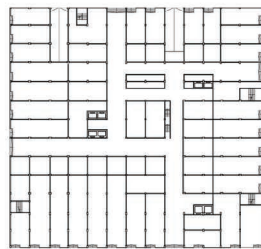

Ground Floor Plan

to twenty occupants, including a three-generation family, and employed shop workers, to live and work together in an eighty meter-square unit.

One block north, Mirador Mansion was already fully managed as a co-operative building in which every tenant owned his/her own shop or apartment. Developed and designed by Harriman Realty, Nathan Road was still densely lined with prewar shop-houses (*tonglaus*) at its completion in 1959. Advertised in 1957 as a “new skyscraper in Kowloon ... with 800 residential and business units,” by the time of the architect’s final submission to the Building Department, the number of units was increased to 1,505! The upper floor plan configuration, composed of units along a

common corridor oriented towards an internal open courtyard, was set up for use as apartment or shop. Fifteen floors of blank units, each equipped with a toilet and kitchen, were built above a commercial podium comprising three floors of shops. By the mid-1960s, on the eve of the street curfew in April 1966, the building had already been flagged out for its shoddy construction and poor maintenance.⁴² As with Chungking Mansions, Mirador Mansion's density was exacerbated by the influx of refugees at the height of the Vietnam War and Cultural Revolution in the Mainland. Their reputation as "problematic buildings" reached a peak in 1988, when two electrical fires — one in Chungking in February and the other in Mirador in August — drew public attention to the buildings' overcrowded conditions and overloaded capacity.⁴³ The Chief Fire Officer of the Fire Protection Bureau estimated that there were at least 1,500 hostels ranging from single rooms to multi-story businesses, although there were only 800 registered addresses.⁴⁴

Rampant subdivision and incessant subletting became the usual practice in these composite buildings. On the one hand, this showed that intense privatization went up to the extent that nobody knew how many people actually lived in these buildings, or who were first-, second- or third-level tenants. The retail podium developed into a trading place that became part of a vertical network of shops with storage spaces on the lower levels, dormitories and owners' homes on the upper levels. This type of interior emporia departed from the contemporary single owner-developer multi-tenanted malls that proliferated in Hong Kong. There were two immediate consequences of the multiple ownerships in the composite building: firstly, the possibility of social mobility for the original owners; secondly, there was little incentive for overall maintenance of the public common spaces and services, which were continually encroached upon. Subsequently, the opening of the Tsuen Wan mass transit railway (MTR) line in 1982, with a stop in Tsim Sha Tsui, saw a further increase in tourist presence on Nathan Road in addition to the substantial number of Indian and Pakistani entrepreneurs and South African traders.⁴⁵ Many of the Indians have already had businesses in the area since earlier in the twentieth century, and others were decommissioned army and police officers turned business operators, whilst most of the Africans were transient residents who found their temporary homes in guesthouses developed in these composite buildings.

The City in a Building, 1990s-present

Dwelling upon the euphoria of development, which has only led to the volumetric transformation of the composite building to the podium-tower configuration, this brief excursion into mid-century Hong Kong offers a glimpse of how the experience of the composite building has been shaped by the very conditions it creates. What if the large-scale composite building, a variant of the utopian megastructures envisioned by the architects attracted in Hong Kong by developers in the latter half of the twentieth century, is allowed to realize its fullest architectural potential of a city in a building? What if dwelling and the city is consummated in the most integrated ways possible? Subsumed by the city's rapid densification and market-driven development, the massive composite building remains standing today as testimony to the kind of pragmatic utopianism that drives and defines Hong Kong's built environment. As a building at a scale that encompasses the complexities and densities of the city, the composite building presents a crucial point of entry for the rethinking and reinvention of the current state of urban habitation and preservation. As housing in Hong Kong still undergoes an unending crisis, architect Szeto Wai's appeal against speculation in his 1959 inaugural address as President of the Hong Kong Society of Architects offers a poignant point of reflection on the current state of affairs:

42 "Mirador in the news – tenants complained about its "slum conditions", *SCMP* (24 Dec. 1965), 6. See also "Hong Kong's fire hazards", *SCMP* (15 Sep. 1966), 2.

43 Jimmy Leung, "Mirador Mansion: Full of problems", *SCMP* (8 Aug. 1988), 3.

44 Gabrielle Chan, "Blaze highlights lack of safety", *SCMP* (8 Aug. 1988), 3.

45 Since the colonial administration, South Africa and Hong Kong had trading relations, with the latter serving as a transit route for air traffic and trade with the rest of the region and China.

“Speculation promotes blight and obsolescence, and it is in the interest of the public that a curb be put on this indiscriminate commercialism. I appeal to all members of this society to exercise their social conscience in performing their professional duties, and to Government to discourage speculative development. Our Professional Practices committee concerns itself with the promulgation and execution of a code of ethics and I would like to suggest that the promotion of this social conscience comes within its province.

As we stand in the threshold of a new decade, let us resolve it will usher in a new era of architecture so that when posterity comes to pass a verdict on our work it will say ‘they were architects indeed’.”⁴⁶

Szeto Wai’s appeal on behalf of the professional body did not anticipate the events that would unfold in the 1960s, with Hong Kong Chinese exodus in specific parts of the city. Many homeowners in composite buildings sold or rented their units and fled to other parts of the city. Most of those who rented did not return to them. Now almost half a century old, the demise of the composite building seems inevitable. Yet, with their multiple ownerships, the co-existence of the illegal and extralegal entities, and the interconnected urban networks in which many of these buildings are a part of, they have become resistant strongholds against speculative development and redevelopment. Paradoxically, although produced by building speculation, they are now amongst the most resilient structures in the city. When demolition is not imminent, under the present pressures of development, many of these large composite buildings are undergoing the transformation into typical *safe* and *generic* mall-environments, subject to perpetual surveillance. Arguably, multi-pronged public and private initiatives to convert them as such were already set in motion the moment their plans were approved in the 1950s.

The mid-century composite building appears to have momentarily side-stepped urban renewal, as the numerous ownerships and tenant subdivisions make it difficult for developers and the government to claim the site as a single legal entity for redevelopment. Far from being a “dinosaur of a future past” — Reyner Banham’s description of the megastructural visions of the period — the composite building is a potential site for continuing reflections on contemporary development, concerning not only the configurations of dwelling units, but also the reinvigoration of actual lived communal spaces. This is especially crucial for a city in which space is closing in on itself, public space is increasingly experienced and defined within air-conditioned consumerist environments, and urban ethnic enclaves are produced with little remedial measures or alternatives. Take for example, Kiu Kwan Mansion and the Metropole Building in North Point. Both were communist hideouts during the 1967 riots; now Kiu Kwan is home to various Fujianese clans in the region, and Metropole contains a large community of medical practitioners; the traffic in and out of these apartment blocks and the ever-changing use of the private and communal spaces worries the building management.

The composite building development in Hong Kong presented itself as a particular insert in the global narrative of modern architecture. It offered a glimpse of the possible coexistence of a contingent population of individuals and collectives dwelling collectively in a continually contested relationship with each other, the developer and the government. Modern architecture in its most recognizable postwar brutalist guise was densely inhabited and vernacularized. The emergence in the late 1960s of the shopping podium and residential high-rise as predominant form up to the present signified a decisive shift from *a city of people* to *a city of surveillance*, since the sharp delineation of the communal circulatory space and individual private space allowed for easy physical and visual control.

In that regard, film director Wong Kar Wai’s oneiric depiction of Chungking Mansions’ interior captured the apex of colonial transition that has come to pass. In 1997, the cultural theorist Ackbar Abbas called the building “a kind of down-market-mall-cum-flophouse”, meaning a “truly

46 Szeto Wai, “Modern Day role of the Architect”, *The Hong Kong & Far East Builder* 14, 5 (1959), 52.



Fig. 05: Left: Ground floor shops from the first floor mezzanine at Chungking Mansions, Tsim Sha Tsui, Kowloon, Hong Kong. Right: Ground floor shops from the first floor mezzanine at Mirador Mansion, Tsim Sha Tsui, Kowloon, Hong Kong.

heterotopic space and living contradiction.⁴⁷ Post-1997, the composite building continued to be occupied by diverse groups and individuals: owners and managers, traders and middlemen, temporary workers, asylum seekers, domestic helpers, sex workers, addicts and tourists.⁴⁸ Everyone was captured in the surveillance system installed by the Incorporated Owners of Chungking Mansions.⁴⁹ A block north, Mirador Mansions — home to a large community of tailors, fabric makers and in recent decades, guesthouses — appeared to be its more introverted counterpart. The first three floors of the podium contain more than 200 shops, while a third of the upper floors consists of a mix of studio apartments, guest houses, tailors and textile traders.⁵⁰ (Fig. 05)

In 2009, the Hong Kong Government, in collaboration with the Hong Kong Housing Society and the Urban Renewal Authority, launched a HK\$1 billion “Operation Building Bright”, to provide subsidies and one-stop technical assistance for owners of about 1,000 30-year old, or more, dilapidated buildings to carry out repair works. On June 30, 2012, the Building Department fully implemented the Mandatory Building Inspection Scheme (MBIS) and the Mandatory Window Inspection Scheme (MWIS), in order to handle the problem of building neglect at source. The majority of buildings to be affected by the two-pronged approach of cleanup and checkup were the half-century old composite buildings. Chungking Mansions was “cleaned up” before the Operation. In 2004, a full security system was installed with television screens mounted at every elevator lobby, and every tenant was listed on its directory. In 2011, on the occasion of the building’s 50th anniversary, the Incorporated Owners enforced an exterior “clean up.” All exterior signage was removed and the entire building façade was painted a homogenous grey. This exterior redressing was heralded by the *Sunday Morning Post* to mark the building’s transformation “from eyesore to icon.”⁵¹ (Fig. 06) Behind the grey homogenous façade, the introverted world of the interior belies a contested surface waiting to be rethought and redesigned.

Yet, the kaleidoscopic environment of Chungking Mansions through the lens of Wong and his cinematographer Christopher Doyle is the “authentic” *other* Hong Kong that visitors still seek when they make their “touristic” pilgrimage to the building complex, for it extends the popular

47 Ackbar Abbas, *Hong Kong: Culture and the Politics of Disappearance* (MN: University of Minnesota Press, 1997), 54.

48 Gordon Matthews, *Ghetto at the Center of the World: Chungking Mansions, Hong Kong* (Hong Kong: Hong Kong University Press, 2011). Rather than focusing on the ethnic representations of the inhabitants, Matthews discussed these groups as specific social categories within the Mansions.

49 In 2011, the building celebrated its 50th anniversary and the news headline read “From eyesore to icon”.

50 The original plan consisted of mainly studio apartments of 500-600 square feet while the corner ones are larger, up to 1,300 square feet.

51 “From eyesore to icon”, *Sunday Morning Post* (7 August, 2011), 4.



Fig. 06: Above: Chungking Mansions. Photograph taken after the façade was “cleaned up” by the Incorporated Owners.
Below: Mirador Mansion. Photograph showing upgrading works for individual units but not yet an overall consolidated “cleaned up” effort like Chungking Mansions one block south.



imagination of illicit activities, clandestine affairs, and ambiguous spaces of triad gangs, grey traders, police chases and hired killers portrayed in Hong Kong films. After the Kowloon Walled City, Chungking Mansions seemed to be the remaining stronghold for the coexistence of the legal, illegal and extra-legal. Anthropologist Alan Smart's year-long field study of the social lives within the building complex added another dimension to the reading of the Chungking Mansions. Rather than celebrating the illegalities, he focused on the agglomeration of multiple ethnicities that passed through the complex, justifying its label as "ghetto at the center of the world."

Smart's appellation is a socio-cultural irony. Whereas a ghetto typically refers to the agglomeration of a similar ethnicity, his study of Chungking reveals that there are at least 120 nationalities that have dwelled in or at least passed through the building complex. Leo Ou-Fan, a keen commentator of Chinese culture, echoed Smart's irony in his 2008 overview of Hong Kong, affirming that "the largely silent Indian minority in Kowloon is scarcely noticed by the Chinese majority."⁵² As such, the title "Ghetto in the World" uncovers the cultural paradox that underpins the identifying formation of modern Hong Kong. In this composite building, the parallel history of a less than racially homogeneous metropolis is played out. It is this interior world, this "jungle" where bodies and things collide and hide, which fascinated film-makers, sociologists, anthropologists and other seekers of alternative culture and history beneath the official "where east meets west" line. Indeed, it was not until Smart's study that a deeper dissection of the building was conducted in order to excavate the *other* city.

Architects and urban planners have invariably stayed away from the discourses of its interior, keeping their distance; at most, they analyzed the singularity of the composite building as a typological massing driven by building regulations. Even its envelope of various cantilevered neon signs, which had excited academics and tourists alike (though a bane to the regulators), has not been a choice site for speculative design intervention. By the time the Incorporated Owners enforced the exterior "clean up" in 2011, the grey homogenous façade of this introverted world of the interior hardly offered itself as a contested surface to be rethought or redesigned. Nevertheless, the composite building is complicit in the narration of Hong Kong's urban history. These buildings manifest a moment in which speculative urban development under the colonial enterprise produced nuanced and fluid spatial associations, to the extent that the limits between the urban and the domestic were perpetually redrawn by the contestations among the various stakeholders. By the 1980s, the single-developer residential tower with commercial podium building type-form replaced the multi-owner volumetric block which was the dominant configuration of the composite building. At the same time, this change marked the beginning of the end of the "composite" in terms of social affiliations and intermingling within these buildings, and portended the urban forms and "generic" spaces of the financial city driven by the rationale of global speculation.

REFERENCE LIST:

- Abbas, Ackbar. *Hong Kong: Culture and the Politics of Disappearance*. MN: University of Minnesota Press, 1997.
- Abercrombie, Patrick. *Hong Kong: Preliminary Planning Report*. Hong Kong: Government Printer, 1949.
- Banham, Reyner. "The New Brutalism". *The Architectural Review* (Dec. 1955): 357.
- Bristow, R. *Land-use Planning in Hong Kong: History, Policies and Procedures*. Hong Kong, Oxford University Press, 1987.
- Chan, Gabrielle. "Blaze highlights lack of safety". *SCMP* (8 August 1988): 3.
- Cheung, Gary Ka-Wai. *Hong Kong's Watershed: The 1967 Riots*. Hong Kong: Hong Kong University Press, 2009.
- Dwyer, D.J. and Lai Chuen-Yan. *The Small Industrial Unit in Hong Kong: Patterns and Policies*. Yorkshire: University of Hull Publication, 1967.
- Feng, Bangyan. *One Hundred Years of Real Estate in Hong Kong [Xianggang di chan ye bai nian 香港地口業百年]*. Shanghai: Oriental Publishing Center, 2007.

⁵² Leo Ou-fan Lee, *Cities Between Worlds: My Hong Kong* (Cambridge, MA; London: Belknap Press of Harvard University Press, 2008), 163.

- Lee, Leo Ou-fan. *Cities Between Worlds: My Hong Kong*. Cambridge, MA; London: Belknap Press of Harvard University Press, 2008.
- Leung, Hon-Chu. "Immigration and citizenship". In *Remaking Citizenship in Hong Kong: Community, nation and the global city*. Edited by Agnes S. Ku and Ngai Pun. London; New York: Routledge, 2004.
- Leung, Jimmy. "Mirador Mansion: Full of problems". *SCMP* (8 August 1988): 3.
- Matthews, Gordon. *Ghetto at the Center of the World: Chungking Mansions, Hong Kong*. Hong Kong: Hong Kong University Press, 2011.
- Sit, Victor. "Hong Kong's 'Transfer' Industrialization and Industrial Geography". *Asian Survey* 38, 9 (Sep. 1998): 903-904.
- Sit, Victor. *Made in Hong Kong*. Hong Kong: Summerson Eastern Publishers Ltd.
- Smith, Charles. "HK's growth generates expectations". *South China Morning Post* (5 July 1971): 32.
- Tsang, Steve. *A Modern History of Hong Kong*. Hong Kong: Hong Kong University Press, 2004.
- Wai, Szeto. "Modern Day role of the Architect". *The Hong Kong & Far East Builder* 14, 5 (1959): 52.
- Whitehead, Kate. "Witnesses to anarchy: the 1967 riots in Hong Kong, by some of those caught up in the violence". *Post Magazine* (25 Apr. 2017). <<http://www.scmp.com/magazines/post-magazine/long-reads/article/2089195/witnesses-anarchy-1967-riots-hong-kong-some-those>>.
- Wong, Fai-Ming. "Industrialization and Family Structure in Hong Kong". *Journal of Marriage and Family* 37, 4 (Nov. 1975).
- Wong, Luke S.K. (ed.). *Housing in Hong Kong*. Hong Kong: Heinemann Educational Books, 1978.
- Xi, Xu. "Chung King Mansion – from Chinese Walls". In *History's Fiction: Stories from the City of Hong Kong*. Hong Kong: Chameleon Press, 2005: 160-183.
- ***. "Curfew in Kowloon, Specific Order for Rigid Enforcement, Enquiry told". *SCMP* (9 June 1966): 8.
- ***. "Density Zoning Adopted". *Far East Architect & Builder* (May 1966): 27-28.
- ***. "Editorial: And Now, Middle Class Co-operative Housing?". *The Hong Kong & Far East Builder* 11, 5 (1955): 5.
- ***. "Empire Court". *The Hong Kong & Far East Builder* 12, 3 (1956): 19-20.
- ***. "From eyesore to icon". *Sunday Morning Post* (7 August 2011): 4.
- ***. "Government Resettlement Work". *The Hong Kong & Far East Builder* 12, 5 (1956): 71-72.
- ***. "Hong Kong's fire hazards". *SCMP* (15 September 1966): 2.
- ***. "Lady Grantham Villas". *The Hong Kong & Far East Builder* 11, 4 (1955): 57-58.
- ***. "Mirador in the news – tenants complained about its 'slum conditions'". *SCMP* (24 December 1965): 6.
- ***. "Mirador Mansion". *The Hong Kong & Far East Builder* 13, 6 (1957-1958): 19-20.
- ***. "Over 100 Workers held three-hour demonstration". *SCMP* (11 May 1967): 6.
- ***. "Police landed from British helicopter, raided Leftists' base in North Point" [“警察乘英艦直升機從天而降 大舉圍搜北角左派巢穴”]. *Kung Sheung Daily News* (5 August 1967): 5.
- ***. "Raids on Three Communist Strongholds: Largest Operations since May". *SCMP* (5 August 1967): 6.
- ***. "Resettlements". *The Hong Kong & Far East Builders* 5, 11 (1955): 62-64 .
- ***. "Tenants leaving 'leftist buildings'". *SCMP* (19 July 1967): 9.
- ***. "Tower Court". *The Hong Kong & Far East Builders* 6, 10 (1953): 9.
- ***. "Well-equipped secret hospital found". *SCMP* (5 August 1967): 6.

ILLUSTRATION CREDITS:

Fig. 01: E.Y. Wu, C.N. Chow and Associates, "Compact Flats in Big Demand by Middle Class", *The Hong Kong & Far East Builder* 19, 1 (1964): 108.

Fig. 02 – 06: Credited by the author, 2012-2014.