



AKADÉMIAI KIADÓ

Journal of Behavioral Addictions

9 (2020) 1, 163-174

DOI:  
10.1556/2006.2020.00004  
© 2020 The Author(s)

FULL LENGTH REPORT



# Smartphone use motivation and problematic smartphone use in a national representative sample of Chinese adolescents: The mediating roles of smartphone use time for various activities

HAORAN MENG<sup>1†</sup>, HONGJIAN CAO<sup>1†</sup> , RUINING HAO<sup>1</sup>, NAN ZHOU<sup>1\*</sup> , YUE LIANG<sup>2</sup> , LULU WU<sup>3</sup>, LIANJIANG JIANG<sup>4</sup>, RONGZI MA<sup>5</sup>, BEILEI LI<sup>1</sup>, LINYUAN DENG<sup>1</sup>, ZHONG LIN<sup>6</sup>, XIUYUN LIN<sup>7</sup>, and JINTAO ZHANG<sup>3,8\*\*</sup>

<sup>1</sup> Faculty of Education, Beijing Normal University, China

<sup>2</sup> School of Education, Guangzhou University, China

<sup>3</sup> State Key Laboratory of Cognitive Neuroscience and Learning and IDG/McGovern Institute for Brain Research, Beijing Normal University, China

<sup>4</sup> Faculty of Education, University of Macau, China

<sup>5</sup> Faculty of Psychology, Beijing Normal University, Beijing, China

<sup>6</sup> School of Foreign Studies, Chang'an University, China

<sup>7</sup> Institute of Developmental Psychology, Beijing Normal University, China

<sup>8</sup> Center for Collaboration and Innovation in Brain and Learning Sciences, Beijing Normal University, China

Received: September 22, 2019 • Revised manuscript received: December 02, 2019 • Accepted: December 21, 2019  
Published online: April 7, 2020

ABSTRACT

*Background and aims:* Previous studies on smartphone use motivation (SUM) and problematic smartphone use (PSU) have been limited in the utilization of regional samples of emerging adults (e.g., college students) and also in the foci on the direct association between SUM and PSU. To address such gaps, using data from a large, national representative sample of Chinese young adolescents and their parents this study examined the associations between adolescents' various types of SUM and their PSU, and also tested the potential mediating roles of smartphone use time (SUT) that adolescents spent on various activities in such associations. *Methods:* A nationwide representative sample of 8,261 Chinese adolescents ( $M_{age} = 12.86$  years old,  $SD = 1.76$ ; 42.6% females) and their parents (49% mothers) participated in this survey study. *Results:* Instrumental SUM (i.e., to expand knowledge or acquire information) was associated negatively with PSU via longer SUT spent on learning and shorter SUT spent on entertainment and communication. Self-expression SUM (i.e., to gain acceptance and recognition of others by maintaining or improving self-images) was associated with longer SUT spent on both learning and entertainment, which, in turn, predicted lower and higher levels of PSU, respectively. Last, hedonic SUM (i.e., to gain pleasure) was associated positively with PSU via longer SUT spent on entertainment and communication. *Discussion:* These findings contribute to the literature by adding greater specificity in our understanding of the implications of SUM and SUT in the etiology of PSU during the critical life stage of adolescence in a Chinese cultural context.

†Haoran Meng and Hongjian Cao contributed equally to the preparation of this manuscript.

\*Corresponding author. Faculty of Education, Beijing Normal University, 528 Ying Dong Building, No. 19 Xin Jie Kou Wai Street, Hai Dian District, Beijing, 100875, China, Tel.: +86 15727317079.  
E-mail: nanzhouchina@gmail.com

\*\*Corresponding author. State Key Laboratory of Cognitive Neuroscience and Learning and IDG/McGovern Institute for Brain Research and Center for Collaboration and Innovation in Brain and Learning Sciences, Beijing Normal University, No. 19 Xin Jie Kou Wai Street, Hai Dian District, Beijing, 100875, China, Tel.: +86 15010233046.  
E-mail: zhangjintao@bnu.edu.cn



**KEYWORDS**

problematic smartphone use, smartphone use motivation, smartphone use time, Chinese adolescents, national representative sample

**INTRODUCTION**

Recent national reports (China Internet Network Information Center, 2016; Ji, Shen, Yang, & Ji, 2018) showed that about 90% of Chinese adolescents used smartphones in their daily lives. Adolescents have relatively lower levels of self-control primarily due to the immaturity of cortical development (Casey & Caudle, 2013; Steinberg, Albert, Cauffman, Banich, Graham, & Woolard, 2008), and they tend to be more enthusiastic about the use of new electronic devices while growing up and living in an era of unprecedented advancements in smart technologies, especially smartphones (Bianchi & Phillips, 2005; Kim, 2017). Therefore, they may be more susceptible to the development of problematic smartphone use (PSU) than adults (Chóliz, 2012; Lopez-Fernandez, Honrubia-Serrano, Freixa-Blanxart, & Gibson, 2013). Furthermore, PSU has also been consistently demonstrated to elevate adolescents' risk for a wide array of developmental problems, including mental disorders (Yen et al., 2009), academic failures (Seo, Park, Kim, & Park, 2016), and interpersonal difficulties (Chen, Yan, Tang, Yang, Xie, & He, 2016).

People are motivated by various needs to use media (Katz, Blumler, & Gurevitch, 1974; LaRose, Lin, & Eastin, 2003; Park, 2010), and thus phone use motivation has long been suggested as a crucial antecedent in the development of PSU (Kardefelt-Winther, 2014). Previous studies have examined associations between different types of phone use motivation and PSU, but these studies have been limited in their utilization of regional samples of college students (Chen, Zhang, Gong, Zhao, Lee, & Liang, 2017; Khang, Kim, & Kim, 2013; Wang, Wang, Gaskin, & Wang, 2015). Moreover, little is known about the mediating mechanisms via which different motivations may contribute to PSU (Chen et al., 2017).

Media use time is a potential mediator, given its associations with both media use motivations (Alhabash, Park, Kononova, Chiang, & Wise, 2012; Hong & Chiu, 2016; Koc & Gulyagci, 2013) and problematic media use (Bae, 2017; Haug, Castro, Min, Filler, Kowatsch, & Schaub, 2015; Lin et al., 2015). Notably, specific types of smartphone use for various activities/goals may have distinct unique effect on PSU. For instance, prior research has demonstrated that excessively using smartphone for online gaming or social interactions might contribute to PSU (Bae, 2017; Salehan & Negahban, 2013; Van Deursen, Bolle, Hegner, & Kommers, 2015), while using smartphone for learning seemed to be unrelated to PSU (Jeong, Kim, Yum, & Hwang, 2016). Thus, differentiating smartphone use time spent on various activities may be a potential avenue to obtain a more nuanced

understanding of how smartphone use time may heighten the risk of PSU.

The current study conducted a process model using data from a large, nationally representative sample of Chinese adolescents ( $N = 8,261$ ). Specifically, we examined (a) whether adolescents' different types of smartphone use motivations (i.e., instrumental, self-expression, hedonic, and social relationship motivations) were differentially associated with their PSU, and also tested (b) the mediating roles of time adolescents spent on various activities when using smartphones (i.e., learning, entertainment, and communication activities) in such associations. By going beyond the monolithic conceptualization of both smartphone use motivation and time, we seek to obtain increased specificity in our understanding of the ways that smartphones shape adolescent development and thus facilitate relevant intervention work to be more targeted.

**Problematic smartphone use**

Excessive and maladaptive use of smartphone has been generally conceptualized within a biomedical framework as a subtype of addictive disorders that resembles Internet addiction (Petry & O'Brien, 2013). However, the conceptualization of smartphone addiction or Internet addiction has been challenged such that the Internet or the smartphone may be just the vector or "delivery mechanism" for a variety of problematic behaviors (e.g., excessive gaming) rather than the problematic behaviors per se (Starcevic & Aboujaoude, 2017). Essentially, this is a spectrum hypothesis that technology-mediated behaviors can be theorized as within "a spectrum of related, yet relatively distinct disorders that may share common and unique etiological factors." (Baggio et al., 2018, p. 6).

Notably, Baggio et al. (2018) tested this hypothesis using a network analysis in a representative sample of 3,404 Swiss young men. They found that Internet addiction was often connected with other problematic behaviors and should be treated as an "umbrella construct" rather than a specific type of addictive behavior, whereas smartphone addiction, along with gaming addiction and cybersex addiction, was identified as an independent construct and a distinct type of addictive behaviors. In accordance with Baggio et al.'s findings, in the present study we conceptualized smartphone addiction as a special type of addictive behaviors that merit more independent examinations. As such, we adopted the term "problematic smartphone use" and used the 9 clinical criteria for Internet Gaming Disorder from DSM-5 to assess the PSU (American Psychiatric Association, 2013).

**Smartphone use motivations and behaviors**

The uses and gratifications (U & G) theory (Katz et al., 1974) assumes that people are active agents in using media and tend to choose and use media based on their own evaluation. This audience-centered proposition indicates that individuals' media use behaviors are primarily driven by their own needs (Rubin, 2009). Accordingly, it is impossible to adequately understand people's media use behaviors without



examining the motivations underlying such behaviors (Park, Kim, Shon, & Shim, 2013; Rubin, 1983, 2009).

Empirical studies have identified multiple types of motivations for media use behaviors (Gan & Li, 2018; Wei, 2008; Yee, 2007). In general, such motivations can be classified into two categories: the habitual (or ritualistic) motivations and the instrumental (or content) motivations (Swanson, 1992). Habitual motivations refer to using the media habitually to spend time for companionship, entertainment, and/or personal identity (e.g., personal reference, reality exploration, and value reinforcement), whereas instrumental motivations refer to using the media for information seeking and/or making arrangements (Livaditi, Vassilopoulou, Lougos, & Chorianopoulos, 2003; Rubin, 2009). Research on Chinese adolescents (Gan & Li, 2018; Ha, Kim, Saenz, Chang, & Park, 2015; Mak et al., 2014) identified some specific types of smartphone use motivations, including self-expression motivations (i.e., to gain acceptance and recognition of others by maintaining or improving self-images; Dominick, 1999; Schlenker & Leary, 1982), hedonic motivations (i.e., to gain pleasurable or joyful experience; Ha et al., 2015), and social relationship motivations (i.e., to establish and maintain social connections with others; Korgaonkar & Wolin, 1999).

To date, a handful of studies have examined the links between smartphone use motivations and PSU with regional, non-representative Chinese samples but yielded mixed results (Chen et al., 2017; Wang et al., 2015; Zhen, Liu, Hong, & Zhou, 2019). For example, Zhen et al. (2019) found that Chinese middle school students with higher levels of social relationship motivation and escape motivation (i.e., use smartphone to escape from problems in reality) tended to engage in more PSU, but these associations were alleviated by the positive parent-child or teacher-student relationships. However, Chen et al. (2017) found that hedonic motivation and peer pressure motivation (i.e., use smartphone due to peer pressure) were positively associated with PSU whereas social relationship motivation was not related to PSU among Chinese university students. As such, the sparseness of relevant research and the inconsistency in existing results call for more examinations based on high-quality Chinese samples to more systematically investigate the associations between smartphone use motivations and PSU.

### The potential mediating role of smartphone use time

Note that in recent years some researchers have advocated the assessment of use time rather than addictive symptoms to screen substance use disorder or Internet use and gaming disorders (Kraus, 2015). This recommendation is primarily based on two considerations: (a) the duration of use time is a critical component of addiction, and (b) individuals tend to under-report their symptoms when filling out self-reported addiction scales due to the worries of stigmatization (Rehm, Probst, Kraus, & Lev-Ran, 2014). However, some empirical studies suggested that use time may not be an accurate or sufficient proxy of addictive or problematic Internet use, given that the two do not overlap/correlate to a large extent

(Baggio et al., 2016; Baggio, Iglesias, Berchtold, & Suris, 2017). For instance, in a sample of 3,054 Swiss adolescents, Baggio et al. (2017) found that (a) the associations between various assessments of Internet use frequency (e.g., use time) and addiction were low to moderate; and (b) the association between addiction and wellbeing (e.g., depression; the comorbid symptoms) were higher than those for indicators of Internet use and wellbeing. As such, the use time ought to be considered as one factor or antecedent of problematic or addictive media use.

Consistent with this notion of use time as a contributing factor to problematic media use, the increases in the smartphone use time may likely elevate the likelihood of PSU (Billieux, 2012). Moreover, the U & G theory suggests that motivations could induce and maintain individuals' engagement in smartphone use (Blumler, 1979; Rubin, 2009; Ruggiero, 2018), which is primarily reflected in the increased amount of time that individuals would devote to using smartphones when they are highly motivated to use smartphones to achieve certain goals. Thus, smartphone use time may serve as a linking mechanism for the association between smartphone use motivations and PSU. In support of this notion, individuals' instrumental, social relationship, and self-presence motivations were found to be associated positively with the amount of time that individuals may spent on social networking like Facebook (Alhabash et al., 2012; Hong & Chui, 2016; Koc & Gulyagci, 2013). Smartphone use time has also been found to be related positively to PSU (Haug et al., 2015; Khang et al., 2013; Lin et al., 2015). However, the potential mediating role of smartphone use time in the link between smartphone use motivation and PSU has not yet been tested.

Moreover, contemporary scholars advocate specifying the distinct roles of individuals' smartphone use behaviors (e.g., specific smartphone use time for various activities) to obtain a more nuanced understanding of how daily smartphone use behaviors contribute to PSU (Billieux, 2012; Van Deursen et al., 2015). Jeong et al. (2016) found in a sample of 944 South Korean children that those who used smartphone for social networking and entertainment were more susceptible to the development of PSU as compared to those who used smartphone for learning. Likewise, Bae (2017) also found that smartphone use for purposeless information-seeking, entertainment, and gaming predicted PSU, whereas smartphone uses for communication (e.g., mobile social network services and instant messenger) were not associated with PSU among Korean middle and high school students. The current study extended these studies by examining adolescents' smartphone use time for learning, entertainment, and communication in the associations between smartphone use motivations and PSU in order to add more specificity in terms of the specific mechanisms for associations between various motivations and PSU.

Overall, based on existing literature, we hypothesized that hedonic and social relationship motivations would be associated positively with PSU, whereas instrumental



motivation would be associated negatively with PSU. We also expected that smartphone use time for entertainment and communication would mediate the associations between PSU and various types of motivations, especially for hedonic and social relationship motivations. In addition, it is possible that smartphone use time for learning would serve as a linking mechanism for the association between instrumental motivation and PSU. Last, given the lack of prior studies examining self-expression motivations, the relevant examination in the present study was exploratory and no specific hypotheses was offered for its associations with smartphone use time and PSU.

## METHOD

### Participants and Procedures

A national survey was conducted among Chinese children, adolescents and their parents. We used the Probability Proportionate to Size Sampling (PPS; Brewer & Gregoire, 2009) method and administrated the questionnaires to parents and children (from the first to the ninth grade) from 31 provinces, autonomous regions, and municipalities across mainland China. The sampling frame was developed by stratifying all cities and counties on the basis of geographic locations (east, central, or west), economic developmental levels (high, medium, or low), levels of urbanization (urban or not) based on the national census data (Ministry of Education of the People's Republic of China, 2017a,b). To obtain a nationally representative sample, a sampling strategy proportional to districts was used. The research protocol was approved by the institutional review board at Beijing Normal Univeristy (No. 2017-0902).

Participants were invited through two ways. The collaborative survey company invited and informed the selected individuals to participate in the survey through phone calls. The survey company also contacted local schools and sent invitations with the assistance of school administrators. A secure online questionnaire link was sent by SMS or e-mail to participants whose consent had been obtained. Given that first to third graders may have difficulties in adequately understanding and independently completing the questionnaires, only parents were invited to complete the parent questionnaire in which the smartphone use motivation, smartphone use time, and PSU were not measured. Notably, it was from the 4<sup>th</sup> grade that the smartphone use motivation or PSU were assessed with self-report survey by children themselves. Typically, the entire survey (including parent and child questionnaires) could be completed within 30 minutes on smartphones, tablets, laptops, or other electronic devices.

Over 100,000 phone calls and invitations were randomly sent out, and ultimately, 11,214 questionnaires were collected (response rate was about 10%) and 11,199 provided valid responses, with 15 duplicate cases removed. In addition, 2,938 participants were removed from the current analytic sample because they did not attend 4th grade and thus did not have self-reported data on smartphone use motivation, smartphone

use time, or PSU. The demographic characteristics of the current sample are displayed in Table 1.

### Measures

**Smartphone use motivations.** A 13-item scale for smartphone use motivations based on prior studies of smartphone use motivations was used (Gan & Li, 2018; Lo & Leung, 2009; Wang et al., 2015). This scale was intended to assess four types of smartphone use motivations: instrumental (1 item, "I use smartphone to expand my knowledge or acquire the information"), self-expression (3 items, e.g., "I use smartphone to show my strengths"), hedonic (5 items, e.g., "I use smartphone to pass time and entertain myself") and social relationship motivations (4 items, e.g., "I use smartphone to get in touch with my old friends"). Items were rated on a 5-point Likert scale ranging from 1 (*very much unlike me*) to 5 (*very much like me*).

Confirmatory Factor Analysis (CFA) was conducted to validate the construct validity of this scale. The designated 4-factor model demonstrated an acceptable model fit to the data:  $\chi^2(60) = 2,567.621$ ,  $P < 0.001$ ; RMSEA = 0.076 with a 90% confidence interval (CI) [0.073, 0.078]; CFA = 0.925; and SRMR = 0.046. Factor loadings ranged from 0.44 to 0.80 ( $ps < 0.001$ ) and the correlations between these four motivations were between 0.27 and 0.83 ( $ps < 0.001$ ). Because Cronbach's  $\alpha$  has been criticized for its biased estimation for reliability (Green & Yang, 2008; Sijtsma, 2008; Zimmerman, Zumbo, & Lalonde, 1993), researchers proposed the composite reliability as a more robust way to estimate the reliability for scales (Bentler, 2009; Raykov, 1997). In the current study, composite reliabilities for self-expression, hedonic, and social relationship motivation were 0.81, 0.76, and 0.78, respectively.

**Smartphone use time for various activities.** Adolescents reported smartphone use time for various activities ("What's your average amount time of smartphone use (minutes) for certain Applications during last week?"), which included smartphone use time for learning (1 item, learning and educational Apps), for entertainment (4 items, including Apps of online games, video watching and music listening, short videos and live streaming, animation comic game (ACG), and other forms of entertainment; items were averaged and used in the analyses), and for communication (1 item, Apps of social networking and instant messaging). Reports of excessive specific smartphone use time (beyond 3 SD) were removed. Specifically, 63 reports of smartphone use time for learning, 58 reports of smartphone use time for entertainment, 125 reports of smartphone use time for communication were removed. The composite reliability was 0.93 in this study.

**Problematic smartphone use.** The nine clinical criteria for Internet Gaming Disorder from DSM-5 (American Psychiatric Association, 2013) was modified to assess PSU. Participants responded "1 = yes" or "2 = no" for each item (e.g., "Whether have you deceived family members, or friends regarding the amount of smartphone use time?"). Given that





Table 1. Descriptive statistics for the sample ( $N = 8,261$ )

Adolescents		<i>n</i>	%	Parents		<i>n</i>	%
Age	10	869	10.5	Relationship with the focal child	Mother	4,049	49.0
<i>M</i> = 12.86	11	1,243	15.0		Father	4,212	51.0
<i>SD</i> = 1.75	12	1,532	18.5	Family annual income (yuan)	Below 1,000	29	0.4
	13	1,422	17.2		1,000–2,000	57	0.7
	14	1,401	17.0		2,000–5,000	499	6.0
	15	1,279	15.5		5,000–8,000	197	2.4
	16	515	6.2		8,000–10,000	299	3.6
Gender	Boys	4,725	57.2		10,000–30,000	632	7.7
	Girls	3,536	42.8		30,000–50,000	830	10.0
Grade	Fourth	1,205	14.6		50,000–100,000	2,776	33.6
	Fifth	1,612	19.5	Educational level	Above 100,000	2,794	33.8
	Sixth	1,296	15.7		Middle school or below	860	10.4
	Seventh	1,675	20.3		High school	2,048	24.8
	Eighth	1,532	18.5		Junior college	2,832	34.3
	Ninth	941	11.4		Undergraduate	2,228	27.0
Living district	Municipality	143	1.7		Graduate or above	293	3.5
Location	Coastal province	2,079	25.2	Age	≤30	1	0.0
	Middle province	3,704	44.8		31–35	1,485	18.0
	West province	2,335	28.3		36–40	3,536	42.8
Living district type	City	6,497	78.6		41–45	2,727	33.0
	Suburb	828	10.0		46–50	445	5.4
	County	936	11.3		51–60	63	0.8
					≥61	4	0.0

the scale used here was binary measured and the conventional coefficient alpha may underestimate the reliability for this type of scales, we adopted a more robust approach of estimating the reliability using latent variable modeling by Raykov, Dimitrov, and Asparouhov (2010) for the scale with dichotomous items. Using this method for estimation, the reliability coefficient of the scale was 0.80. CFA was conducted to validate the construct validity of this scale. The one-factor model demonstrated an adequate model fit to the data:  $\chi^2(27) = 616.912$ ,  $P < 0.001$ ; RMSEA = 0.055 with a 90% confidence interval (CI) [0.051, 0.059]; CFA = 0.969. Factor loadings ranged from 0.60 to 0.79 ( $ps < 0.001$ ). Given the original cutoff of 5 out of 9 items, 2,948 (valid percent = 40.4%) adolescents were deemed to be addictive smartphone users; however, this statistic should be interpreted with caution given the screening rather than diagnostic nature of the scale.

**Demographic covariates.** Covariates include: Adolescents' age in years, gender ("1 = boy" or "2 = girl"), grade (first to ninth grade), and parents' relationship with adolescent children ("1 = father", "2 = mother", "3 = other guardian"), age in years, and educational levels ("1 = middle school or below", "2 = high school", "3 = junior college", "4 = undergraduate", or "5 = graduate or above"), family income, and living district location ("1 = middle province", "2 = west province", "3 = coastal province", or "4 = municipality") and type ("1 = city", "2 = suburb", or "3 = county"). These variables were considered given their associations with study variables (Beison & Rademacher, 2017; Chen et al., 2017; Van Deursen et al., 2015).

## Analytic Approach

Hypotheses were tested using structural equation modeling via Mplus 7.4 (Muthén & Muthén, 1992–2015). Full Information Maximum Likelihood estimation was used to handle missing data. Model adequacy was evaluated with multiple indices: the non-significant chi-square with its degree of freedom ( $\chi^2$ ), the root mean square error of approximation (RMSEA; acceptable < 0.08, good < 0.05) with its 90% confidence interval (CI), the comparative fit index (CFI; acceptable > 0.90, good > 0.95), and the standardized root mean square residual (SRMR; acceptable < 0.08, good < 0.05) (Kline, 2015). However, when the sample size is large, a significant  $\chi^2$  should be often expected (Byrne, 2013). Indirect effects were assessed using bootstrapping (Preacher & Hayes, 2008). The standard errors (S.E.) and confidence intervals (CIs) for indirect effects were based on 2,000 bootstrap resamples.

## Ethics

This study was approved by the institutional review board at Beijing Normal University, China (IRB #2017-0902), with all the participants providing electronic or written informed consent.

## RESULTS

Descriptive statistics and correlations of key variables and covariates are shown in Table 2. Most of the correlations

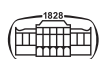

Table 2. Descriptive statistics and correlations among key variables and covariates

	1	2	3	4	5	6	7	8
1. PSU	–							
2. MPUT-Learning	<b>–0.08</b>	–						
3. MPUT-Entertainment	<b>0.06</b>	<b>0.67</b>	–					
4. MPUT-Communication	<b>0.13</b>	<b>0.61</b>	<b>0.71</b>	–				
5. Instrumental motivation	<b>–0.22</b>	<b>0.14</b>	0.02	0.00	–			
6. Self-expression motivation	<b>0.10</b>	<b>0.21</b>	<b>0.14</b>	<b>0.09</b>	<b>0.25</b>	–		
7. Social relationship motivation	<b>0.09</b>	<b>0.15</b>	<b>0.12</b>	<b>0.09</b>	<b>0.25</b>	<b>0.49</b>	–	
8. Hedonic motivation	<b>0.21</b>	<b>0.17</b>	<b>0.18</b>	<b>0.14</b>	<b>0.23</b>	<b>0.58</b>	<b>0.64</b>	–
Covariates								
Age	<b>–0.03</b>	<b>0.04</b>	<b>0.20</b>	<b>0.16</b>	<b>0.09</b>	<b>0.05</b>	<b>0.03</b>	<b>0.07</b>
Gender	<b>–0.13</b>	<b>–0.06</b>	<b>–0.09</b>	<b>–0.11</b>	0.01	<b>–0.14</b>	<b>–0.07</b>	<b>–0.11</b>
Grade	<b>–0.05</b>	<b>0.08</b>	<b>0.19</b>	<b>0.14</b>	<b>0.08</b>	<b>0.04</b>	<b>0.02</b>	<b>0.07</b>
Relationship	<b>–0.08</b>	<b>–0.13</b>	<b>–0.10</b>	<b>–0.15</b>	–0.01	<b>–0.17</b>	<b>–0.05</b>	<b>–0.12</b>
Parent's age	<b>–0.05</b>	0.01	<b>0.09</b>	0.03	<b>0.15</b>	<b>0.06</b>	0.01	<b>0.04</b>
Educational level	–0.01	<b>0.10</b>	0.01	<b>–0.03</b>	<b>0.14</b>	<b>0.20</b>	<b>0.16</b>	<b>0.18</b>
District location	<b>0.05</b>	<b>0.11</b>	<b>0.12</b>	<b>0.05</b>	<b>0.05</b>	<b>0.10</b>	<b>0.05</b>	<b>0.08</b>
District type	<b>0.09</b>	–0.02	<b>0.07</b>	<b>0.04</b>	<b>–0.15</b>	<b>–0.14</b>	<b>–0.09</b>	<b>–0.08</b>
Family annual income	–0.01	<b>0.12</b>	<b>0.17</b>	0.02	<b>0.22</b>	<b>0.12</b>	<b>0.16</b>	<b>0.17</b>
Mean	3.60	0.13	0.13	0.13	3.80			
SD	2.61	0.13	0.13	0.14	1.09			
n	7,292	3,420	6,556	4,397	7,292			

Note: Bolded coefficients were significant at  $P < 0.05$  (two-tailed) level; the factor scores of the latent variables were computed by adding the products of their corresponding items and the factor loadings of the items; PSU, problematic smartphone use; MPUT-Learning, smartphone use time for learning; MPUT-Entertainment, smartphone use time for entertainment; MPUT-Communication, smartphone use time for communication.

between key variables were in the expected directions. The potential differential mediating roles of specific smartphone use time in the association between smartphone use motivations and PSU were examined (Fig. 1). This model demonstrated a good fit:  $\chi^2(177) = 3274.986$ ,  $P < 0.001$ ; RMSEA = 0.046 with a 90% CI, [0.045, 0.047]; CFA = 0.926; and SRMR = 0.030. Instrumental motivation ( $\beta = -0.232$ ,  $P < 0.001$ ), hedonic motivation ( $\beta = 0.418$ ,  $P < 0.001$ ), and social relationship motivation ( $\beta = -0.167$ ,  $P < 0.001$ ) were directly associated with PSU.

Furthermore, the indirect pathways were examined by the bias-corrected bootstrapped estimates (Table 3). Instrumental motivation was negatively associated with PSU via smartphone use time for learning ( $\beta = -0.031$ ,  $P < 0.001$ ), entertainment ( $\beta = -0.010$ ,  $P < 0.001$ ), and communication ( $\beta = -0.004$ ,  $P < 0.05$ ). Specifically, instrumental motivation was positively associated with smartphone use time for learning ( $\beta = 0.102$ ,  $P < 0.001$ ) which was negatively associated with PSU ( $\beta = -0.303$ ,  $P < 0.001$ ); instrumental motivation was negatively associated with smartphone use time for entertainment ( $\beta = -0.063$ ,  $P < 0.001$ ) and communication ( $\beta = -0.040$ ,  $P < 0.05$ ) which were both positively associated with PSU ( $\beta = 0.162$ ,  $P < 0.001$ , for entertainment;  $\beta = 0.107$ ,  $P < 0.001$ , for communication).

The indirect effects between self-expression motivation and PSU via smartphone use time for learning ( $\beta = -0.048$ ,  $P < 0.001$ ) and entertainment ( $\beta = 0.008$ ,  $P < 0.05$ ) were significant. Self-expression motivation was positively associated with smartphone use time for learning ( $\beta = 0.160$ ,  $P < 0.001$ ) and entertainment ( $\beta = 0.051$ ,  $P < 0.05$ ), which, in turn, predicted less and more PSU, respectively.

As for hedonic motivation, it was indirectly and positively associated with PSU via smartphone use time for entertainment ( $\beta = 0.028$ ,  $P < 0.001$ ) and communication ( $\beta = 0.016$ ,  $P < 0.01$ ). Hedonic motivation significantly increased the time spent on entertainment ( $\beta = 0.172$ ,  $P < 0.001$ ) and communication ( $\beta = 0.152$ ,  $P = 0.001$ ) which were both positively associated with PSU. In terms of effect sizes, standardized indirect effects 0.01 were interpreted as “small”, 0.09 as “medium”, and 0.25 as “large” (Kenny, 2012). The magnitudes of all the currently identified indirect effects were between “small” and “medium.”

## DISCUSSION

Most teenagers use smartphones in their daily lives to communicate with each other (e.g., call, send messages, e-mails) or to have fun (e.g., watch videos and play games) but rarely use smartphone to engage in academic activities (e.g., finding learning materials) (Jacobsen & Forste, 2011). Given that Chinese parents and teachers tend to be more focused on children's academic performance (Bai, Ma, Liu, Zhang, & Rasool, 2019), a better understanding of various types of smartphone use motivations (including academic and non-academic motivations) and how these motivations relate to their smartphone use and PSU will provide insights for parents and teachers as well as policy makers to promote their instrumental use rather than entertainment use.

Using data from a large, nationally representative sample of Chinese adolescents, the current study examined the



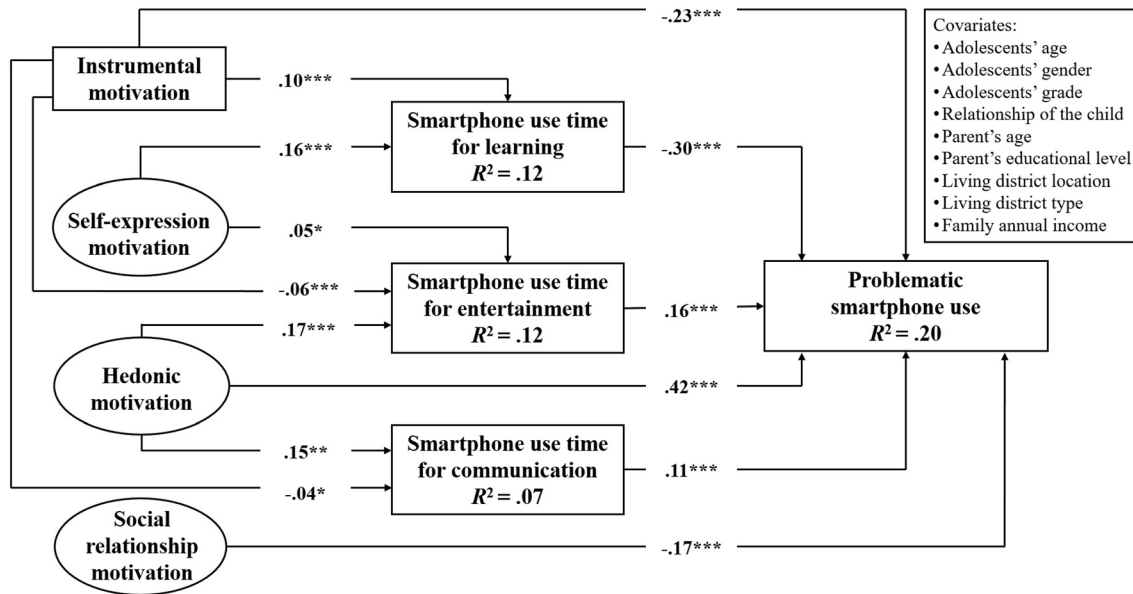

Figure 1. Model results for the associations among different types of smartphone use motivation and PSU, with smartphone use time spent on various activities tested as potential mediators. Note: Only significant pathways are depicted for clarity. Standardized coefficients are reported. The lines and coefficients for correlations among smartphone use motivations, specific smartphone use time, and covariates are omitted for clarity. \* $P < 0.05$ ; \*\* $P < 0.01$ ; \*\*\* $P < 0.001$  (two-tailed)

Table 3. Specific indirect effects for indirect pathways based on bias-corrected bootstrapped estimates (Specific smartphone use time as mediators)

Specific indirect pathways tested	Bootstrapped estimates for indirect effects			
	<i>b</i>	<i>SE</i>	95% CI	$\beta$
<b>Instrumental motivation → PSU</b>				
MPUT-Learning	-0.074	0.014	[-0.103, -0.049]	-0.031
MPUT-Entertainment	-0.024	0.006	[-0.039, -0.014]	-0.010
MPUT-Communication	-0.010	0.005	[-0.022, -0.003]	-0.004
<b>Self-expression motivation → PSU</b>				
MPUT-Learning	-0.138	0.025	[-0.189, -0.093]	-0.048
MPUT-Entertainment	0.024	0.012	[0.004, 0.050]	0.008
MPUT-Communication	-0.002	0.008	[-0.018, 0.013]	-0.001
<b>Hedonic motivation → PSU</b>				
MPUT-learning	-0.003	0.050	[-0.113, 0.092]	-0.001
MPUT-Entertainment	0.107	0.028	[0.059, 0.169]	0.028
MPUT-Communication	0.063	0.022	[0.029, 0.116]	0.016
<b>Social relationship motivation → PSU</b>				
MPUT-learning	-0.005	0.035	[-0.070, 0.067]	-0.002
MPUT-Entertainment	-0.020	0.017	[-0.057, 0.012]	-0.006
MPUT-Communication	-0.004	0.013	[-0.029, 0.023]	-0.001

Note: Bolded indirect pathways were significant based on bias-corrected bootstrapped 95% confidence interval (CI). PSU, problematic smartphone use; MPUTL, smartphone use time for learning; MPUTE, smartphone use time for entertainment; MPUTC, smartphone use time for communication; *b*, unstandardized coefficient; *SE*, standard error; *CI*, confidence interval for the unstandardized coefficient;  $\beta$ , standardized coefficient.

associations between various types of smartphone use motivation and PSU and tested the mediating roles of smartphone use time for various activities in such associations. We found that the direct association between instrumental motivation and PSU was negative, whereas hedonic

motivation could directly and positively predict PSU. In terms of the mediating roles of smartphone use time for various activities, instrumental motivation was associated negatively with PSU via more time spent on learning and less time spent on entertainment and communication; self-

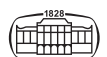

expression motivation was associated positively with time spent on learning and entertainment, which, in turn, predicted PSU; hedonic motivation was associated positively with PSU by increasing the time spent on entertainment and communication. These findings contribute to the literature by adding greater specificity in our understanding of the implications of mobile phone use motivations and time in the etiology of PSU during the critical life stage of adolescence in a Chinese cultural context.

### The Association between Smartphone use Motivations and PSU

The identified negative associations between instrumental motivation and PSU converge with those of previous studies (Khang et al., 2013; Park, 2005). Adolescents with high levels of instrumental motivation are goal-oriented and may use smartphones as a tool to interact with the outside world (Livaditi et al., 2003; Rubin, 2009; Song, LaRose, Eastin, & Lin, 2004). They would keep away from the smartphone after achieving their goals (e.g., searching for information or learning), which would decrease the risk for the development of PSU. In contrast, adolescents with high levels of hedonic motivation tend to indulge into the virtual world via smartphone given that their gratifications directly come from the medium itself (Rubin, 1984, 2009; Song et al., 2004). Therefore, their affinity with the smartphone may be more likely to lead to PSU as a result.

Inconsistent with previous studies (Chen et al., 2017; Khang et al., 2013; Zhen et al., 2019), a negative direct association between social relationship motivation and PSU was identified. Note that Chinese adolescents use smartphones mainly to keep in touch with their family or close friends rather than making new friends or communicating with strangers (Ji et al., 2018). In fact, these two forms of relationship connections are labeled as “strong ties” and “weak ties,” respectively (Ellison, Steinfield, & Lampe, 2007). As revealed in prior research, people engaging in strong ties would be more likely to receive sufficient social support (Gilbert & Karahalios, 2009; Heaney & Israel, 2008), which would reduce their risk for developing PSU (Shaw & Gant, 2004; Wang, Zhang, & Zeng, 2019). Future studies differentiating these two forms of social relationship motivation and their respective, unique associations with PSU are needed to provide a more nuanced understanding of under what circumstances and with what motivations to keep social ties with others via smartphone would contribute to PSU.

### The Mediating Roles of Smartphone use Time for Various Activities

The current study further examined the mediating roles of the specific smartphone use time. First, people with high levels of instrumental motivation were less likely to develop PSU by enhancing the time spent on learning and by decreasing the time spent on entertainment and communication. It makes sense given that instrumental motivation in

Chinese adolescents is mostly learning-based (i.e., using smartphone to expand knowledge) and these goal-oriented adolescents would turn to other activities instead of still wallowing in smartphone uses when knowledge or information has been obtained (Livaditi et al., 2003; Rubin, 2009; Song et al., 2004).

Second, self-expression motivation predicted longer time spent on learning, which, in turn, would decrease the chance of PSU. Given the extremely fierce competitions in the Chinese academic contexts and long-term traditions in considering bringing glory and honor to family through the achievement of academic success, adolescents may be driven by their self-presence motivations to using smartphone to facilitate their learning (Watkins, 2007, 2010). Their determination in achieving high performance and self-control in using smartphone in learning rather than entertainment could significantly decrease their risk in developing PSU (Jeong et al., 2016; Ross & Broh, 2000). Meanwhile, self-expression motivation related positively to the time spent on entertainment (e.g., online gaming), which, in turn, was associated positively with PSU. Online gaming may enable another way of self-expression by creating an online self-image adolescents desire and/or comparing with others to demonstrate their capacities (Park & Chung, 2011; Walther & Burgoon, 1992). By this way, this self-expression motivation would make adolescents more committed to online game (Park & Chung, 2011), which could further lead to PSU (Khang et al., 2013).

Finally, hedonic motivation was associated positively with PSU by increasing the time spent on entertainment and communication. Nowadays, Chinese adolescents are facing enormous stress from academic demands and interpersonal issues (Chen et al., 2016; Liu & Lu, 2012). To alleviate potential negative moods associated with stress (Kardefelt-Winther, 2014; Kim, 2017; Wang et al., 2015), their hedonic motivation would be highly activated to engage in online gaming or social networking via smartphones (Gan & Li, 2018; Ha et al., 2015; Khang et al., 2013). However, escaping from the reality and immersing in the virtual reality might ultimately render PSU (Kardefelt-Winther, 2014; Wang et al., 2015).

Importantly, as discussed earlier, smartphone may not be just a vector for a variety of problematic behaviors and PSU should be treated as a distinct type of addictive behaviors (Baggio et al., 2018). However, the current identification of differentiated mediating roles of smartphone use time for different activities suggests that future studies may consider specifying some subtypes of PSU, like problematic smartphone gaming. Research in such directions may help obtain a more nuanced understanding of the associations between smartphone use time and PSU.

### Limitations and Future Directions

Limitations of the present study and directions for future research should be noted. First, smartphone use motivations are dynamic in nature and may vary across different specific smartphone applications. In the current study we adapted a scale originally developed for assessing social media and





messaging applications (Gan & Li, 2018; Lo & Leung, 2009; Wang et al., 2015), which might not adequately capture the dynamic or specific motivations for different applications. Thus, time-series analyses based on scales specifically developed for smartphone motivations can be utilized in future studies to capture nuanced changes in smartphone application motivations or their associations with PSU.

Second, the IGD-9 scale was originally developed for measuring Internet gaming disorder and may not be completely suitable for assessing PSU (Sigerson, Li, Cheung, Luk, & Cheng, 2017). Moreover, certain behaviors/symptoms should be frequently repeated or present to meet the diagnosing criteria of IGD in the DSM-5, which may not be captured by the binary rating scale (i.e., yes or no) used in the IGD-9 instrument (Király, Slezcka, Pontes, Urban, Griffiths, & Demetrovics, 2017). However, given that an extensive set of constructs were assessed in the national project from which the present data were derived, to avoid bringing participants too much cognitive burden we did not ask parents or adolescents to fill out multiple-rating scales (e.g., a 5-point rating scale) for many constructs, including the PSU, and the use of such assessing strategies are not uncommon in large national survey research. Nevertheless, we acknowledge that this utilization may not capture the full range of the relevant constructs, and our findings await to be replicated by future studies that use a multiple-rating scale instrument that is particularly designated for assessing PSU.

Third, most key variables in the questionnaire were reported only by adolescents, which may result in common method bias. Moreover, cross-sectional design in this study prevented from causal inference based on the findings. Thus, future studies are warranted to use multiple informants and methods and longitudinal designs to replicate the findings in this study. Last, the accuracy of the reported smartphone use time has been questioned given the potential underestimation of one's own media use, especially among excessive users (Hong & Chiu, 2016; Lin et al., 2015; Rau, Peng, & Yang, 2006). Thus, future studies may utilize specific Apps to capture media use time (Lin et al., 2015), or use multiple indicators (e.g., time and intensity) to represent smartphone use (Alhabash et al., 2012; Dhir & Tsai, 2017).

## CONCLUSION AND IMPLICATIONS

Our results demonstrated that adolescents' different smartphone use motivations as well as smartphone use time for various activities would distinctively affect their susceptibility to PSU. Thus, both smartphone use motivations and time should be taken into account to reduce adolescents' risk for PSU. Given the central focus on academic achievement in the Chinese society, Chinese parents and teachers tend to forbid children's smartphone use without considering the various types of smartphone use motivation and use for different activities (Bai et al., 2019). Based on our findings, Chinese

parents and teachers should instruct adolescents to more engage in learning activities with the assistance of smartphones rather than excessive entertainment activities. In fact, Chinese adolescents should be informed that excessive entertainment use of smartphone may undermine their mastery goals orientation (i.e., the focus is on developing rather than demonstrating competence), which is essential for their future success (Bai et al., 2019; Dweck, 2013). Moreover, we may not only pay attention to adolescents' overall amount of smartphone use time, but also consider the sub-amount of smartphone use time for various activities for more targeted interventions, especially monitoring the time on entertainment and communication (Bae, 2017; Jeong et al., 2016; Salehan & Negahban, 2013).

*Funding sources:* Preparation of this article was supported by: (a) the National Natural Science Foundation of China (31700966, 31871122, and 31800937); (b) the Open Research Fund of the State Key Laboratory of Cognitive Neuroscience and Learning (CNLZD1802); and (c) the Fundamental Research Funds for the Central Universities (2018NTSS06 and 2019NTSS04).

*Authors' contribution:* H-RM, H-JC, and NZ were responsible for the study conceptualization and design and drafted the entire manuscript. H-RM, NZ, L-LW, and J-TZ contributed to the data collection. H-RM, R-NH, NZ, YL, L-JJ, and R-ZM conducted data analyses. H-RM, H-JC, and NZ, B-LL, L-YD, ZL, X-YL, and J-TZ polished the manuscript by providing edits and comments. All authors had full access to all data in the study and take responsibility for the data integrity and the accuracy of analyses. All authors had reviewed the content thoroughly and approved the final version of the current manuscript for publication.

*Conflict of interest:* The authors declare that they have no conflict of interest.

## REFERENCES

- Alhabash, S., Park, H., Kononova, A., Chiang, Y., & Wise, K. (2012). Exploring the motivations of Facebook use in Taiwan. *Cyberpsychology, Behavior, and Social Networking, 15*, 304–311. <https://doi.org/10.1089/cyber.2011.0611>.
- American Psychiatric Association. (2013). *Diagnostic and statistical manual of mental disorders DSM-5*. Washington, DC: American Psychiatric Publishing.
- Bae, S. M. (2017). The relationship between the type of smartphone use and smartphone dependence of Korean adolescents: National survey study. *Children and Youth Services Review, 81*, 207–211. <https://doi.org/10.1016/j.childyouth.2017.08.012>.
- Baggio, S., Dupuis, M., Studer, J., Spilka, S., Daeppen, J. B., Simon, O., et al. (2016). Reframing video gaming and internet use addiction: Empirical cross-national comparison of heavy use over time and addiction scales among young users. *Addiction, 111*, 513–522. <https://doi.org/10.1111/add.13192>.



- Baggio, S., Iglesias, K., Berchtold, A., & Suris, J. C. (2017). Measuring internet use: Comparisons of different assessments and with internet addiction. *Addiction Research and Theory*, 25, 114–120. <https://doi.org/10.1080/16066359.2016.1206083>.
- Baggio, S., Starcevic, V., Studer, J., Simon, O., Gainsbury, S. M., Gmel, G., et al. (2018). Technology-mediated addictive behaviors constitute a spectrum of related yet distinct conditions: A network perspective. *Psychology of Addictive Behaviors*, 32, 564–572. <https://doi.org/10.1037/adb0000379>.
- Bai, R., Ma, Y., Liu, Y., Zhang, B., & Rasool, A. (2019). The relationship between cellphone use and achievement goals in junior high school students: A cross-lagged analysis. *Psychology in the Schools*, 56, 891–906. <https://doi.org/10.1002/pits.22252>.
- Beison, A., & Rademacher, D. J. (2017). Relationship between family history of alcohol addiction, parents' education level, and smartphone problem use scale scores. *Journal of Behavioral Addictions*, 6, 84–91. <https://doi.org/10.1556/2006.6.2017.016>.
- Bentler, P. M. (2009). Alpha, dimension-free, and model-based internal consistency reliability. *Psychometrika*, 74, 137–143. <https://doi.org/10.1007/s11336-008-9100-1>.
- Bianchi, A., & Phillips, J. G. (2005). Psychological predictors of problem mobile phone use. *CyberPsychology and Behavior*, 8, 39–51. <https://doi.org/10.1089/cpb.2005.8.39>.
- Billieux, J. (2012). Problematic use of the mobile phone: A literature review and a pathways model. *Current Psychiatry Reviews*, 8, 299–307. <https://doi.org/10.2174/157340012803520522>.
- Blumler, J. G. (1979). The role of theory in uses and gratifications studies. *Communication Research*, 6, 9–36. <https://doi.org/10.1177/009365027900600102>.
- Brewer, K. & Gregoire, T. G. (2009). Introduction to survey sampling. In Pfeiffermann, D., Rao, C. R. (Eds.). *Sample surveys: Design, methods and applications*. (Vol. 29A, pp. 9–37). Amsterdam, Netherlands: Elsevier.
- Byrne, B. M. (2013). *Structural equation modeling with Mplus: Basic concepts, applications, and programming*. New York, NY: Routledge.
- Casey, B. J., & Caudle, K. (2013). The teenage brain: Self control. *Current Directions in Psychological Science*, 22, 82–87. <https://doi.org/10.1177/0963721413480170>.
- Chen, L., Yan, Z., Tang, W., Yang, F., Xie, X., & He, J. (2016). Mobile phone addiction levels and negative emotions among Chinese young adults: The mediating role of interpersonal problems. *Computers in Human Behavior*, 55, 856–866. <https://doi.org/10.1016/j.chb.2015.10.030>.
- Chen, C., Zhang, K. Z. K., Gong, X., Zhao, S. J., Lee, M. K. O., & Liang, L. (2017). Examining the effects of motives and gender differences on smartphone addiction. *Computers in Human Behavior*, 75, 891–902. <https://doi.org/10.1016/j.chb.2017.07.002>.
- China Internet Network Information Center. (2016). *Research report on Chinese adolescents' Internet use behaviors by 2015*. Retrieved from <http://www.cnnic.cn/hlwfzyj/hlwzxbg/qsnbg/201608/P020160812393489128332.pdf>.
- Chóliz, M. (2012). Mobile-phone addiction in adolescence: The test of mobile phone dependence (TMD). *Progress in Health Sciences*, 2, 33–44.
- Dhir, A., & Tsai, C. C. (2017). Understanding the relationship between intensity and gratifications of Facebook use among adolescents and young adults. *Telematics and Informatics*, 34, 350–364. <https://doi.org/10.1016/j.tele.2016.08.017>.
- Dominick, J. R. (1999). Who do you think you are? Personal home pages and self-presentation on the world wide web. *Journalism and Mass Communication Quarterly*, 76, 646–658. <https://doi.org/10.1177/107769909907600403>.
- Dweck, C. S. (2013). *Self-theories: Their role in motivation, personality, and development*. Philadelphia, PA: Psychology press.
- Ellison, N. B., Steinfield, C., & Lampe, C. (2007). The benefits of Facebook "friends:" Social capital and college students' use of online social network sites. *Journal of Computer-Mediated Communication*, 12, 1143–1168. <https://doi.org/10.1111/j.1083-6101.2007.00367.x>.
- Gan, C., & Li, H. (2018). Understanding the effects of gratifications on the continuance intention to use WeChat in China: A perspective on uses and gratifications. *Computers in Human Behavior*, 78, 306–315. <https://doi.org/10.1016/j.chb.2017.10.003>.
- Gilbert, E., & Karahalios, K. (2009). Predicting tie strength with social media. *Proceedings of the 27th International Conference on Human Factors in Computing Systems – CHI 09*. <https://doi.org/10.1145/1518701.1518736>.
- Green, S. B., & Yang, Y. (2008). Commentary on coefficient alpha: A cautionary tale. *Psychometrika*, 74, 121–135. <https://doi.org/10.1007/s11336-008-9098-4>.
- Ha, Y. W., Kim, J., Libaque-Saenz, C. F., Chang, Y., & Park, M. C. (2015). Use and gratifications of mobile SNSs: Facebook and KakaoTalk in Korea. *Telematics and Informatics*, 32, 425–438. <https://doi.org/10.1016/j.tele.2014.10.006>.
- Haug, S., Castro, R. P., Kwon, M., Filler, A., Kowatsch, T., & Schaub, M. P. (2015). Smartphone use and smartphone addiction among young people in Switzerland. *Journal of Behavioral Addictions*, 4, 299–307. <https://doi.org/10.1556/2006.4.2015.037>.
- Heaney, C. A., & Israel, B. A. (2008). Social networks and social support. In Glanz, K., Rimer, B. K., & Viswanath, K. (Eds.). *Health behavior and health education: Theory, research, and practice* (pp. 189–210). San Francisco, CA: John Wiley & Sons.
- Hong, F. Y., & Chiu, S. L. (2016). Factors influencing Facebook usage and Facebook addictive tendency in university students: The role of online psychological privacy and Facebook usage motivation. *Stress and Health*, 32, 117–127. <https://doi.org/10.1002/smi.2585>.
- Jacobsen, W. C., & Forste, R. (2011). The wired generation: Academic and social outcomes of electronic media use among university students. *Cyberpsychology, Behavior and Social Networking*, 14, 275–280. <https://doi.org/10.1089/cyber.2010.0135>.
- Jeong, S. H., Kim, H. J., Yum, J. Y., & Hwang, Y. (2016). What type of content are smartphone users addicted to?: SNS vs. games. *Computers in Human Behavior*, 54, 10–17. <https://doi.org/10.1016/j.chb.2015.07.035>.
- Ji, W. M., Shen, J., Yang, B. Y., & Ji, L. (2018). *Annual report of the Internet use and reading practice of Chinese minors (2017~2018)* (pp. 71–89). Beijing, China: Social Sciences Academic Press.
- Kardefelt-Winther, D. (2014). A conceptual and methodological critique of Internet addiction research: Towards a model of compensatory Internet use. *Computers in Human Behavior*, 31, 351–354. <https://doi.org/10.1016/j.chb.2013.10.059>.
- Katz, E., Blumler, J. G., & Gurevitch, M. (1974). Utilization of mass communication by the individual. In Blumler, J. G. &



- Katz, E. (Eds.). *The uses of mass communications: Current perspectives on gratifications research* (pp. 19–32). Beverly Hills, CA: Sage.
- Kenny, D. A. (2012). *Mediation*. Retrieved from <http://davidakenny.net/cm/mediate.htm>.
- Khang, H., Kim, J. K., & Kim, Y. (2013). Self-traits and motivations as antecedents of digital media flow and addiction: The Internet, mobile phones, and video games. *Computers in Human Behavior*, 29, 2416–2424. <https://doi.org/10.1016/j.chb.2013.05.027>.
- Kim, J. H. (2017). Smartphone-mediated communication vs. face-to-face interaction: Two routes to social support and problematic use of smartphone. *Computers in Human Behavior*, 67, 282–291. <https://doi.org/10.1016/j.chb.2016.11.004>.
- Király, O., Slezcka, P., Pontes, H. M., Urbán, R., Griffiths, M. D., & Demetrovics, Z. (2017). Validation of the ten-item Internet Gaming Disorder Test (IGDT-10) and evaluation of the nine DSM-5 Internet Gaming Disorder criteria. *Addictive Behaviors*, 64, 253–260. <https://doi.org/10.1016/j.addbeh.2015.11.005>.
- Kline, R. B. (2015). *Principles and practice of structural equation modeling* (pp. 262–299). New York, NY: Guilford.
- Koc, M., & Gulyagci, S. (2013). Facebook addiction among Turkish college students: The role of psychological health, demographic, and usage characteristics. *Cyberpsychology, Behavior, and Social Networking*, 16, 279–284. <https://doi.org/10.1089/cyber.2012.0249>.
- Korgaonkar, P. K., & Wolin, L. D. (1999). A multivariate analysis of web usage. *Journal of Advertising Research*, 39(2), 53–68.
- Kraus, L. (2015). PL-05: Reframing addictions: Is the concept of "heavy use over time" also applicable to gambling disorders?. *Journal of Behavioral Addictions*, 4(S1), 3–5.
- LaRose, R., Lin, C. A., & Eastin, M. S. (2003). Unregulated Internet usage: Addiction, habit, or deficient self-regulation? *Media Psychology*, 5, 225–253. [https://doi.org/10.1207/s1532785xmep0503\\_01](https://doi.org/10.1207/s1532785xmep0503_01).
- Lin, Y. H., Lin, Y. C., Lee, Y. H., Lin, P. H., Lin, S. H., Chang, L. R., et al. (2015). Time distortion associated with smartphone addiction: Identifying smartphone addiction via a mobile application (App). *Journal of Psychiatric Research*, 65, 139–145. <https://doi.org/10.1016/j.jpsychires.2015.04.003>.
- Liu, Y., & Lu, Z. (2012). Chinese high school students' academic stress and depressive symptoms: Gender and school climate as moderators. *Stress and Health*, 28, 340–346. <https://doi.org/10.1002/smi.2418>.
- Livaditi, J., Vassilopoulou, K., Lougos, C., & Chorianopoulos, K. (2003). Needs and gratifications for interactive TV implications for designers. *Proceedings of the 36th Hawaii International Conference on System Sciences*. <https://doi.org/10.1109/hicss.2003.1174237>.
- Lo, O. W. Y., & Leung, L. (2009). Effects of gratification-opportunities and gratifications-obtained on preferences of instant messaging and e-mail among college students. *Telematics and Informatics*, 26, 156–166. <https://doi.org/10.1016/j.tele.2008.06.001>.
- Lopez-Fernandez, O., Honrubia-Serrano, L., Freixa-Blanxart, M., & Gibson, W. (2013). Prevalence of problematic mobile phone use in British adolescents. *Cyberpsychology, Behavior, and Social Networking*, 17, 91–98. <https://doi.org/10.1089/cyber.2012.0260>.
- Mak, K.-K., Lai, C.-M., Watanabe, H., Kim, D.-I., Bahar, N., Ramos, M., et al. (2014). Epidemiology of Internet behaviors and addiction among adolescents in six Asian countries. *Cyberpsychology, Behavior, and Social Networking*, 17, 720–728. <https://doi.org/10.1089/cyber.2014.0139>.
- Ministry of Education of the People's Republic of China. (2017a). *Number of students in junior secondary schools*. Retrieved from [http://en.moe.gov.cn/documents/statistics/2016/region/201708/t20170823\\_311739.html](http://en.moe.gov.cn/documents/statistics/2016/region/201708/t20170823_311739.html).
- Ministry of Education of the People's Republic of China. (2017b). *Number of students in primary schools (Total)*. Retrieved from [http://en.moe.gov.cn/documents/statistics/2016/region/201708/t20170824\\_311868.html](http://en.moe.gov.cn/documents/statistics/2016/region/201708/t20170824_311868.html).
- Park, W. K. (2005). Mobile phone addiction. In Rich, L. & Per, E. (Eds.). *Mobile communications* (pp. 253–272). London, UK: Springer-Verlag.
- Park, N. (2010). Adoption and use of computer-based voice over Internet protocol phone service: Toward an integrated model. *Journal of Communication*, 60, 40–72. <https://doi.org/10.1111/j.1460-2466.2009.01440.x>.
- Park, S. B., & Chung, N. (2011). Mediating roles of self-presentation desire in online game community commitment and trust behavior of Massive Multiplayer Online Role-Playing Games. *Computers in Human Behavior*, 27, 2372–2379. <https://doi.org/10.1016/j.chb.2011.07.016>.
- Park, N., Kim, Y. C., Shon, H. Y., & Shim, H. (2013). Factors influencing smartphone use and dependency in South Korea. *Computers in Human Behavior*, 29, 1763–1770. <https://doi.org/10.1016/j.chb.2013.02.008>.
- Petry, N. M., & O'Brien, C. P. (2013). Internet gaming disorder and the DSM-5. *Addiction*, 108, 1186–1187. <https://doi.org/10.1111/add.12162>.
- Preacher, K. J., & Hayes, A. F. (2008). Asymptotic and resampling strategies for assessing and comparing indirect effects in multiple mediator models. *Behavior Research Methods*, 40, 879–891. <https://doi.org/10.3758/BRM.40.3.879>.
- Rau, P.-L. P., Peng, S.-Y., & Yang, C.-C. (2006). Time distortion for expert and novice online game players. *CyberPsychology and Behavior*, 9, 396–403. <https://doi.org/10.1089/cpb.2006.9.396>.
- Raykov, T. (1997). Estimation of composite reliability for congeneric measures. *Applied Psychological Measurement*, 21, 173–184. <https://doi.org/10.1177/01466216970212006>.
- Raykov, T., Dimitrov, D. M., & Asparouhov, T. (2010). Evaluation of scale reliability with binary measures using latent variable modeling. *Structural Equation Modeling*, 17, 265–279. <https://doi.org/10.1080/10705511003659417>.
- Rehm, J., Probst, C., Kraus, L., & Lev-Ran, S. (2014). *The addiction concept revisited. Reframing addictions: Policies, processes and pressures* (pp. 102–116). Barcelona: The ALICE RAP project.
- Ross, C. E., & Broh, B. A. (2000). The roles of self-esteem and the sense of personal control in the academic achievement process. *Sociology of Education*, 73, 270–284. <https://doi.org/10.2307/2673234>.
- Rubin, A. M. (1983). Television uses and gratifications: The interactions of viewing patterns and motivations. *Journal of Broadcasting*, 27, 37–51. <https://doi.org/10.1080/08838158309386471>.
- Rubin, A. M. (1984). Ritualized and instrumental television viewing. *Journal of Communication*, 34, 67–77. <https://doi.org/10.1111/j.1460-2466.1984.tb02174.x>.

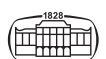



- Rubin, A. M. (2009). Uses-and-gratifications perspective of media effects. In Bryant, J., Oliver, M. B. (Eds.). *Media effects: Advances in theory and research* (pp. 165–184). New York, NY: Routledge.
- Ruggiero, T. E. (2018). Uses and gratifications theory in the 21st century. *Refining Milestone Mass Communications Theories for the 21st Century*, 3, 36–70. <https://doi.org/10.4324/9781315679402-4>.
- Salehan, M., & Negahban, A. (2013). Social networking on smartphones: When mobile phones become addictive. *Computers in Human Behavior*, 29, 2632–2639. <https://doi.org/10.1016/j.chb.2013.07.003>.
- Schlenker, B. R., & Leary, M. R. (1982). Social anxiety and self-presentation: A conceptualization model. *Psychological Bulletin*, 92, 641–669. <https://doi.org/10.1037/0033-2909.92.3.641>.
- Seo, D. G., Park, Y., Kim, M. K., & Park, J. (2016). Mobile phone dependency and its impacts on adolescents' social and academic behaviors. *Computers in Human Behavior*, 63, 282–292. <https://doi.org/10.1016/j.chb.2016.05.026>.
- Shaw, L. H., & Gant, L. M. (2004). In defense of the Internet: The relationship between Internet communication and depression, loneliness, self-esteem, and perceived social support. *CyberPsychology and Behavior*, 5, 157–171. <https://doi.org/10.1089/109493102753770552>.
- Sigerson, L., Li, A. Y. L., Cheung, M. W. L., Luk, J. W., & Cheng, C. (2017). Psychometric properties of the Chinese internet gaming disorder scale. *Addictive Behaviors*, 74, 20–26. <https://doi.org/10.1016/j.addbeh.2017.05.031>.
- Sijtsma, K. (2008). On the use, the misuse, and the very limited usefulness of Cronbach's Alpha. *Psychometrika*, 74, 107–120. <https://doi.org/10.1007/s11336-008-9101-0>.
- Song, I., Larose, R., Eastin, M. S., & Lin, C. A. (2004). Internet gratifications and Internet addiction: On the uses and abuses of new media. *CyberPsychology and Behavior*, 7, 384–394. <https://doi.org/10.1089/cpb.2004.7.384>.
- Starcevic, V., & Aboujaoude, E. (2017). Internet addiction: Reappraisal of an increasingly inadequate concept. *CNS Spectrums*, 22, 7–13. <https://doi.org/10.1017/S1092852915000863>.
- Steinberg, L., Albert, D., Cauffman, E., Banich, M., Graham, S., & Woolard, J. (2008). Age differences in sensation seeking and impulsivity as indexed by behavior and self-report: Evidence for a dual systems model. *Developmental Psychology*, 44, 1764–1778. <https://doi.org/10.1037/a0012955>.
- Swanson, D. L. (1992). Understanding audiences: Continuing contributions of gratifications research. *Poetics*, 21, 305–328. [https://doi.org/10.1016/0304-422X\(92\)90011-Q](https://doi.org/10.1016/0304-422X(92)90011-Q).
- Van Deursen, A. J. A. M., Bolle, C. L., Hegner, S. M., & Kommers, P. A. M. (2015). Modeling habitual and addictive smartphone behavior: The role of smartphone usage types, emotional intelligence, social stress, self-regulation, age, and gender. *Computers in Human Behavior*, 45, 411–420. <https://doi.org/10.1016/j.chb.2014.12.039>.
- Walther, J. B., & Burgoon, J. K. (1992). Relational communication in computer-mediated interaction. *Human Communication Research*, 19, 50–88. <https://doi.org/10.1111/j.1468-2958.1992.tb00295.x>.
- Wang, J. L., Wang, H. Z., Gaskin, J., & Wang, L. H. (2015). The role of stress and motivation in problematic smartphone use among college students. *Computers in Human Behavior*, 53, 181–188. <https://doi.org/10.1016/j.chb.2015.07.005>.
- Wang, G., Zhang, W., & Zeng, R. (2019). WeChat use intensity and social support: The moderating effect of motivators for WeChat use. *Computers in Human Behavior*, 91, 244–251. <https://doi.org/10.1016/j.chb.2018.10.010>.
- Watkins, D. (2007). The nature of competition: The views of students from three regions of the People's Republic of China. In Salili, F., & Hoosain, R. (Eds.). *Culture, motivation, and learning: A multicultural perspective* (pp. 217–233). Charlotte, NC: Information Age Publishing.
- Watkins, D. A. (2010). Motivation and competition in Hong Kong secondary schools: The students' perspective. In Chan, C. K., & Rao, N. (Eds.). *Revisiting the Chinese learner* (pp. 71–88). Hong Kong, China: Comparative Education Research Centre.
- Wei, R. (2008). Motivations for using the mobile phone for mass communications and entertainment. *Telematics and Informatics*, 25, 36–46. <https://doi.org/10.1016/j.tele.2006.03.001>.
- Yee, N. (2007). Motivations for play in online games. *Cyber Psychology and Behavior*, 9, 772–775. <https://doi.org/10.1089/cpb.2006.9.772>.
- Yen, C. F., Tang, T. C., Yen, J. Y., Lin, H. C., Huang, C. F., Liu, S. C., et al. (2009). Symptoms of problematic cellular phone use, functional impairment and its association with depression among adolescents in Southern Taiwan. *Journal of Adolescence*, 32, 863–873. <https://doi.org/10.1016/j.adolescence.2008.10.006>.
- Zhen, R., Liu, R. D., Hong, W., & Zhou, X. (2019). How do interpersonal relationships relieve adolescents' problematic mobile phone use? The roles of loneliness and motivation to use mobile phones. *International Journal of Environmental Research and Public Health*, 16, 2286. <https://doi.org/10.3390/ijerph16132286>.
- Zimmerman, D. W., Zumbo, B. D., & Lalonde, C. (1993). Coefficient alpha as an estimate of test reliability under violation of two assumptions. *Educational and Psychological Measurement*, 53, 33–49. <https://doi.org/10.1177/0013164493053001003>.

